

VSH MG

Puša za ojačenje cevi

HANSA FLEX

Lastnosti

Način izdelave puše za ojačenje

Material: med

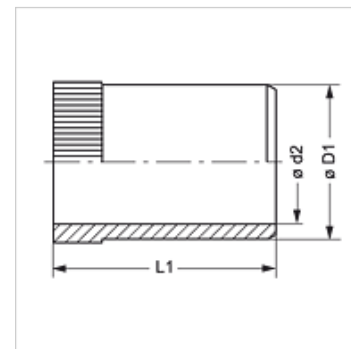

Artikel

Opis	za notranji Ø cevi (mm)	Ø D1 (mm)	Ø d2 (mm)	L1 (mm)
VSH 04 ID MG	4,0	3,8	2,6	15,5
VSH 04.5 ID MG	4,5	4,3	3,1	14,0
VSH 05 ID MG	5,0	4,8	3,6	14,0
VSH 06 ID MG	6,0	5,8	4,6	15,5
VSH 07 ID MG	7,0	6,8	5,6	17,0
VSH 08 ID MG	8,0	7,8	6,6	16,5
VSH 09 ID MG	9,0	8,8	7,6	16,5
VSH 10 ID MG	10,0	9,8	8,6	16,5
VSH 11 ID MG	11,0	10,8	9,6	15,5
VSH 12 ID MG	12,0	11,8	10,2	17,0
VSH 13 ID MG	13,0	12,8	11,2	17,0
VSH 14 ID MG	14,0	13,8	12,2	17,0
VSH 15 ID MG	15,0	14,8	13,2	17,5
VSH 16 ID MG	16,0	15,8	14,2	17,5
VSH 17 ID MG	17,0	16,8	15,2	18,0
VSH 18 ID MG	18,0	17,8	16,2	22,0
VSH 19 ID MG	19,0	18,8	17,2	18,0
VSH 20 ID MG	20,0	19,8	18,2	18,0
VSH 21 ID MG	21,0	20,8	19,2	20,0
VSH 22 ID MG	22,0	21,8	20,2	23,5
VSH 24 ID MG	24,0	23,8	22,2	18,0
VSH 25 ID MG	25,0	24,8	23,2	18,0
VSH 26 ID MG	26,0	25,8	24,2	21,0
VSH 31 ID MG	31,0	30,8	28,8	22,5
VSH 32 ID MG	32,0	31,8	29,2	22,5
VSH 38 ID MG	38,0	37,8	35,8	23,5

Variante izdelka

VSH Puša za ojačenje cevi, jeklo

VSH VA Puša za ojačenje cevi, nerjavno jeklo