

### Lastnosti

<b>Priključek 1</b>	metrični zunanji navoj, cilindrični
<b>Oblika tesnila 1</b>	obroč s tesnilnim robom
<b>Priključek 2 + 3</b>	metrični zunanji navoj, cilindrični
<b>Oblika tesnila 2 + 3</b>	24° notranji konus
<b>Način izdelave</b>	obračalni vijačni priključek brez dušenja
<b>Oblika izdelave</b>	izvedba T
<b>Standard</b>	ISO 8434-1
<b>Obseg dobave</b>	nastavek (brez prekrivne matice in rezalnega obroča)
<b>Material:</b>	jeklo
<b>Zaščita površine</b>	galvanično prevlečeno

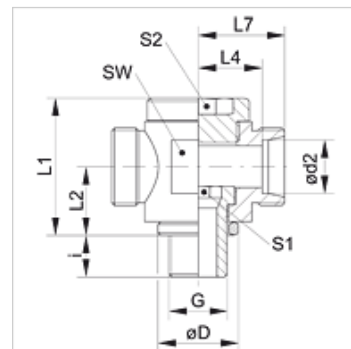

### Navodilo

Za navodila za montažo, vgradnjo, obremenitev s tlakom in dovoljene temperature delovanja si, prosimo, oglejte tehnične podatke za navojne cevne priključke.

### Artikel

Opis	Serijska	Obratovalni tlak bar	Ø d2 (mm)	G	Ø D (mm)	i (mm)	L1 (mm)	L2 (mm)	L4 (mm)	L7 (mm)	SW (mm)	S1	S2
XDTM NW 04 HL	L	PN 160	6	M 10 x 1	14,0	8	24	12	12,0	19	19	6	6
XDTM NW 06 HL	L	PN 160	8	M 12 x 1,5	17,0	12	27	14	13,0	20	22	6	6
XDTM NW 08 HL	L	PN 100	10	M 14 x 1,5	19,0	12	30	15	15,0	22	22	8	8
XDTM NW 10 HL	L	PN 100	12	M 16 x 1,5	21,0	12	36	18	17,5	24	27	10	10
XDTM NW 13 HL	L	PN 100	15	M 18 x 1,5	23,0	12	39	19	20,0	27	30	12	12
XDTM NW 16 HL	L	PN 100	18	M 22 x 1,5	27,0	14	41	20	20,5	28	32	14	14
XDTM NW 20 HL	L	PN 100	22	M 26 x 1,5	31,0	16	46	22	24,5	32	36	17	17
XDTM NW 25 HL	L	PN 100	28	M 33 x 2	39,0	18	58	29	29,5	37	46	22	22
XDTM NW 32 HL	L	PN 63	35	M 42 x 2	49,0	20	69	33	33,0	44	55	27	27
XDTM NW 40 HL	L	PN 63	42	M 48 x 2	55,0	22	84	41	40,0	51	70	32	32
XDTM NW 03 HS	S	PN 160	6	M 12 x 1,5	17,0	12	27	14	15,0	22	22	6	6
XDTM NW 04 HS	S	PN 160	8	M 14 x 1,5	19,0	12	30	15	16,0	23	22	8	8
XDTM NW 06 HS	S	PN 100	10	M 16 x 1,5	21,0	12	36	18	18,0	25	27	10	10
XDTM NW 08 HS	S	PN 100	12	M 18 x 1,5	23,0	12	39	19	26,0	27	30	12	12
XDTM NW 10 HS	S	PN 100	14	M 20 x 1,5	25,0	14	41	20	22,0	30	32	12	12
XDTM NW 13 HS	S	PN 100	16	M 22 x 1,5	27,0	14	45	22	23,5	32	36	14	14
XDTM NW 16 HS	S	PN 100	20	M 27 x 2	32,0	16	58	28	28,5	39	46	17	17
XDTM NW 20 HS	S	PN 100	25	M 33 x 2	39,0	18	62	31	31,0	43	50	22	22
XDTM NW 25 HS	S	PN 63	30	M 42 x 2	49,0	20	74	36	36,5	50	60	27	27
XDTM NW 32 HS	S	PN 63	38	M 48 x 2	55,0	22	84	41	41,0	57	70	32	32

serija: LL = zelo lahko L = lahko S = težko - PN = nazivni tlak PB = maks. obratovalni tlak - Ø d2 = zunanji premer cevi

### Variante izdelka

<b>XDTM VA</b>	Obračalni vijačni spoj, brez dušenja, izvedba T, nastavek (brez prekrivne matice in rezalnega obroča)
<b>DTM</b>	Obračalni vijačni spoj, brez dušenja, izvedba T, nastavek s prekrivno matico in rezalnim obročem