

Lastnosti

Priključek 1	varilni nastavek za metrično cev
Oblika tesnila 2	24° zunanji konus s tesnilnim obročem
Način izdelave	privarilni tesnilni konus
Oblika izdelave	ravno
Standard	DIN 3865
Material:	nerjavno jeklo

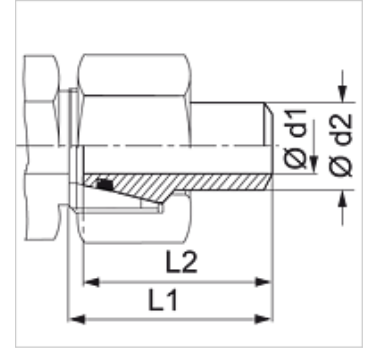

Navodilo

Za navodila za montažo, vgradnjo, obremenitev s tlakom in dovoljene temperature delovanja si, prosimo, oglejte tehnične podatke za navojne cevne priključke.

Navodila za naročanje

NBR tesnila
FPM (Viton) na zahtevo

Artikel

Opis	Serijska	Obratovalni tlak bar	Ø d1 (mm)	Ø d2 (mm)	L1 (mm)	L2 (mm)	OR
SA NW 13 DKOL 1.5 VA	L	PN 270	12	15	38,0	36,0	12,0 x 2,0
SA NW 13 DKOL 2 VA	L	PN 315	11	15	38,0	36,0	12,0 x 2,0
SA NW 13 DKOL 2.5 VA	L	PN 315	10	15	35,0	34,5	12,0 x 2,0
SA NW 16 DKOL 1.5 VA	L	PN 225	15	18	39,0	37,0	15,0 x 2,0
SA NW 16 DKOL 2.0 VA	L	PN 300	14	18	39,0	37,0	15,0 x 2,0
SA NW 16 DKOL 2.5 VA	L	PN 315	13	18	37,0	36,0	15,0 x 2,0
SA NW 20 DKOL 2.0 VA	L	PN 160	18	22	40,5	38,5	20,0 x 2,0
SA NW 20 DKOL 2.5 VA	L	PN 160	17	22	39,5	37,5	20,0 x 2,0
SA NW 20 DKOL 3.0 VA	L	PN 160	16	22	40,5	38,5	20,0 x 2,0
SA NW 25 DKOL 2.0 VA	L	PN 160	24	28	43,5	41,5	26,0 x 2,0
SA NW 25 DKOL 2.5 VA	L	PN 160	23	28	53,0	48,0	26,0 x 2,0
SA NW 25 DKOL 3 VA	L	PN 160	22	28	42,5	47,0	26,0 x 2,0
SA NW 32 DKOL 2.0 VA	L	PN 154	31	35	49,0	47,0	32,0 x 2,5
SA NW 32 DKOL 2.5 VA	L	PN 160	30	35	49,0	47,0	32,0 x 2,5
SA NW 32 DKOL 3.0 VA	L	PN 160	29	35	49,0	47,0	32,0 x 2,5
SA NW 32 DKOL 3.5 VA	L	PN 160	28	35	49,5	47,0	32,0 x 2,5
SA NW 32 DKOL 4 VA	L	PN 160	27	35	49,0	47,0	32,0 x 2,5
SA NW 40 DKOL 2.0 VA	L	PN 160	38	42	49,0	47,0	38,0 x 2,5
SA NW 40 DKOL 2.5 VA	L	PN 160	37	42	49,0	47,0	38,0 x 2,5
SA NW 40 DKOL 3 VA	L	PN 160	36	42	50,0	47,0	38,0 x 2,5
SA NW 40 DKOL 4 VA	L	PN 160	34	42	49,0	47,0	38,0 x 2,5

serijska: LL = zelo lahko L = lahko S = težko -- PN = nazivni tlak PB = maks. obratovalni tlak -- d2 = za zunanji premer cevi

Variante izdelka

SA DKOL Privarilni tesnilni konus, jeklo