

### Lastnosti

<b>Priključek 1</b>	metrični zunanji navoj konusni
<b>Oblika tesnila 1</b>	tesni navoje
<b>Priključek 2</b>	metrični zunanji navoj, cilindrični
<b>Oblika tesnila 2</b>	24° notranji konus
<b>Način izdelave</b>	uvojni vijajni priključek
<b>Oblika izdelave</b>	ravno
<b>Standard</b>	DIN 2353 ISO 8434-1
<b>Obseg dobave</b>	nastavek (brez prekrivne matice in rezalnega obroča)
<b>Material:</b>	jeklo
<b>Zaščita površine</b>	galvanično prevlečeno

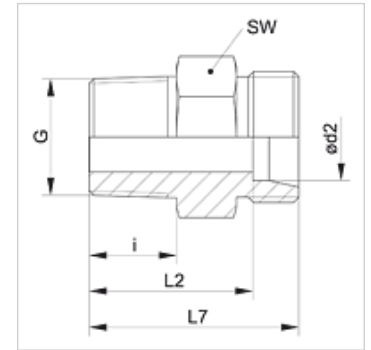

### Navodilo

Za navodila za montažo, vgradnjo, obremenitev s tlakom in dovoljene temperature delovanja si, prosimo, oglejte tehnične podatke za navojne cevne priključke.

### Artikel

Opis	Seriya	Obratovalni tlak bar	Ø d2 (mm)	G	i (mm)	L2 (mm)	L7 (mm)	SW (mm)
XVM 04 LL 6	LL	PN 100	4	M 6 x 1 K	8	16,0	20	9
XVM 04 LL	LL	PN 100	4	M 8 x 1 K	8	16,0	20	9
XVM 04 LL 10	LL	PN 100	4	M 10 x 1 K	8	16,0	20	11
XVM 05 LL	LL	PN 100	5	M 8 x 1 K	8	14,5	20	11
XVM 06 LL 6	LL	PN 100	6	M 6 x 1 K	8	14,5	20	11
XVM 06 LL 8	LL	PN 100	6	M 8 x 1 K	8	14,5	20	11
XVM 06 LL	LL	PN 100	6	M 10 x 1 K	8	14,5	20	11
XVM 08 LL	LL	PN 100	8	M 10 x 1 K	8	16,5	22	12
XVM 12 LL	LL	PN 100	12	M 16 x 1,5 K	12	21,0	27	19
XVMK NW 04 HL	L	PN 315	6	M 10 x 1 K	8	15,0	22	12
XVMK NW 06 HL	L	PN 315	8	M 12 x 1,5 K	12	20,0	27	14
XVMK NW 08 HL	L	PN 315	10	M 14 x 1,5 K	12	21,0	28	17
XVMK NW 10 HL	L	PN 315	12	M 16 x 1,5 K	12	22,0	29	19
XVMK NW 13 HL	L	PN 315	15	M 18 x 1,5 K	12	23,0	30	24
XVMK NW 16 HL	L	PN 315	18	M 22 x 1,5 K	14	25,5	33	27
XVMK NW 20 HL	L	PN 160	22	M 26 x 1,5 k	18	31,5	39	32
XVMK NW 25 HL	L	PN 160	28	M 33 x 2 K	20	34,5	42	41
XVMK NW 32 HL	L	PN 160	35	M 42 x 2 K	21	35,5	46	46
XVMK NW 40 HL	L	PN 160	42	M 48 x 2 K	22	38,0	49	55
XVMK NW 03 HS	S	PN 630	6	M 12 x 1,5 K	12	24,0	31	14

serija: LL = zelo lahko L = lahko S = težko – PN = nazivni tlak PB = maks. obratovalni tlak – Ø d2 = zunanji premer cevi

### Variante izdelka

<b>XVMK VA</b>	Uvojni vijajni spoj, nerjavno jeklo
<b>VMK</b>	Uvojni vijajni spoj, jeklo