

### Lastnosti

<b>Način izdelave</b>	priključek za črpalko (3 luknje)
<b>Oblika izdelave</b>	koleno 90°
<b>Pritrditev</b>	s kompletom metričnih vijakov
<b>Obseg dobave</b>	s kompletom metričnih vijakov in tesnilnim obročem
<b>Material:</b>	jeklo ST 42.3
<b>Zaščita površine</b>	galvanično prevlečeno

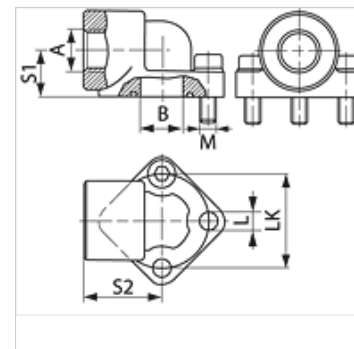

### Artikel

Opis	Tlak PB (bar)	LK (mm)	A	B (mm)	S1 (mm)	S2 (mm)	L (mm)	Vijaki	OR
<b>WDS 0.5 12</b>	315	26	G 1/2" -14	11,0	17	24	5,3	(3 x) M 5 x 20	14,00 x 1,78
<b>WDS 0.5 38</b>	315	26	G 3/8" -19	11,0	17	24	5,3	(3 x) M 5 x 20	14,00 x 1,78
<b>WDS 1 12</b>	315	30	G 1/2" -14	12,0	17	24	6,3	(3 x) M 6 x 20	15,88 x 2,62
<b>WDS 1 38</b>	315	30	G 3/8" -19	12,0	17	24	6,3	(3 x) M 6 x 20	15,88 x 2,62
<b>WDS 2 12</b>	315	40	G 1/2" -14	19,0	21	36	8,5	(3 x) M 8 x 25	23,81 x 2,62
<b>WDS 2 34</b>	315	40	G 3/4" -14	19,0	21	36	8,5	(3 x) M 8 x 25	23,81 x 2,62
<b>WDS 3 100</b>	315	51	G 1" -11	24,0	26	45	10,5	(3 x) M 10 x 30	31,42 x 2,62
<b>WDS 3 34</b>	315	51	G 3/4" -14	26,0	26	45	10,5	(3 x) M 10 x 30	31,42 x 2,62
<b>WDS 3 B 100</b>	315	56	G 1" -11	26,0	26	45	10,5	(3 x) M 10 x 30	31,42 x 2,62
<b>WDS 3 B 34</b>	315	56	G 3/4" -14	26,0	26	45	10,5	(3 x) M 10 x 30	31,42 x 2,62

PN = nazivni tlak PB = maks. obratovalni tlak