

BZL VA / BZS VA

Zapora brez krovne matice

HANSA FLEX

Lastnosti

Oblika tesnila 1 24° zunanji konus s tesnilnim obročem

Način izdelave zapora brez prekrivne matice

Oblika izdelave ravno

Standard DIN 2353
ISO 8434-1

Material: nerjavno jeklo

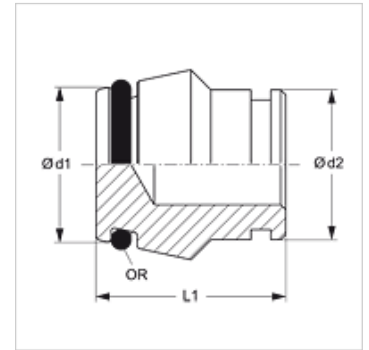

Navodilo

Za navodila za montažo, vgradnjo, obremenitev s tlakom in dovoljene temperature delovanja si, prosimo, oglejte tehnične podatke za navojne cevne priključke.

Artikel

Opis	Serijska	Obratovalni tlak bar	Ø d1 (mm)	Ø d2 (mm)	L1 (mm)	OR
BZL NW 04 VA	L	PN 315	6,6	6	18,5	4,0 x 1,5
BZL NW 06 VA	L	PN 315	8,5	8	18,0	6,0 x 1,5
BZL NW 08 VA	L	PN 315	10,6	10	19,5	7,5 x 1,5
BZL NW 10 VA	L	PN 315	12,6	12	19,0	9,0 x 1,5
BZL NW 13 VA	L	PN 315	15,5	15	19,0	12,0 x 2,0
BZL NW 16 VA	L	PN 315	18,6	18	22,0	15,0 x 2,0
BZL NW 20 VA	L	PN 160	22,6	22	22,0	20,0 x 2,0
BZL NW 25 VA	L	PN 160	28,5	28	23,5	26,0 x 2,0
BZL NW 32 VA	L	PN 160	36,0	35	27,0	32,0 x 2,5
BZL NW 40 VA	L	PN 160	43,0	42	27,5	38,0 x 2,5
BZS NW 03 VA	S	PN 630	-	6	18,5	4,0 x 1,5
BZS NW 04 VA	S	PN 630	-	8	18,5	6,0 x 1,5
BZS NW 06 VA	S	PN 630	-	10	20,0	7,5 x 1,5
BZS NW 08 VA	S	PN 630	-	12	20,5	9,0 x 1,5
BZS NW 10 VA	S	PN 630	14,5	14	21,0	10,0 x 2,0
BZS NW 13 VA	S	PN 400	16,5	16	22,0	12,0 x 2,0
BZS NW 16 VA	S	PN 400	20,9	20	26,5	16,0 x 2,5
BZS NW 20 VA	S	PN 400	25,9	25	27,5	20,0 x 2,5
BZS NW 25 VA	S	PN 400	31,0	30	28,5	25,0 x 2,5
BZS NW 32 VA	S	PN 315	39,0	38	32,5	33,0 x 2,5

serija: LL = zelo lahko L = lahko S = težko - PN = nazivni tlak PB = maks. obratovalni tlak - Ø = zunanji premer cevi

Variante izdelka

BZL / BZS Zapora brez krovne matice, jeklo

BZL / BZS MG Zapora brez krovne matice, med