

# VLM VA / VSM VA

## Zaporna matica

### Lastnosti

Priključek 1	metrična matica
Oblika tesnila 1	24° zunanji konus s tesnilnim obročem
Način izdelave	zaporna matica
Oblika izdelave	ravno
Standard	DIN 2353 ISO 8434-1
Material:	nerjavno jeklo

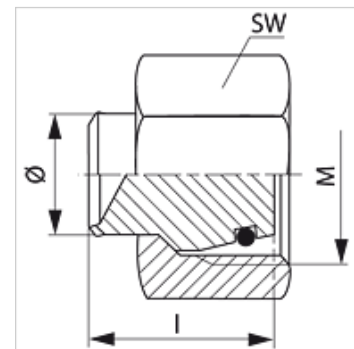

### Navodilo

Za navodila za montažo, vgradnjo, obremenitev s tlakom in dovoljene temperature delovanja si, prosimo, oglejte tehnične podatke za navojne cevne priključke.

### Artikel

Opis	Serija	Obratovalni tlak bar	Zunanji Ø cevi (mm)	M	I (mm)	SW (mm)	OR
VLM NW 04 VA	L	PN 400	6	M 12 x 1,5	18,5	14	4,0 x 1,5
VLM NW 06 VA	L	PN 400	8	M 14 x 1,5	18,0	17	6,0 x 1,5
VLM NW 08 VA	L	PN 400	10	M 16 x 1,5	19,5	19	7,5 x 1,5
VLM NW 10 VA	L	PN 400	12	M 18 x 1,5	19,0	22	9,0 x 1,5
VLM NW 13 VA	L	PN 400	15	M 22 x 1,5	19,0	27	12,0 x 2,0
VLM NW 16 VA	L	PN 315	18	M 26 x 1,5	22,0	32	15,0 x 2,0
VLM NW 20 VA	L	PN 315	22	M 30 x 2	22,0	36	20,0 x 2,0
VLM NW 25 VA	L	PN 250	28	M 36 x 2	23,5	41	26,0 x 2,0
VLM NW 32 VA	L	PN 250	35	M 45 x 2	27,0	50	32,0 x 2,5
VLM NW 40 VA	L	PN 250	42	M 52 x 2	27,5	60	38,0 x 2,5
VSM NW 03 VA	S	PN 630	6	M 14 x 1,5	18,5	17	4,0 x 1,5
VSM NW 04 VA	S	PN 630	8	M 16 x 1,5	18,0	19	6,0 x 1,5
VSM NW 06 VA	S	PN 630	10	M 18 x 1,5	19,5	22	7,5 x 1,5
VSM NW 08 VA	S	PN 630	12	M 20 x 1,5	19,0	24	9,0 x 1,5
VSM NW 10 VA	S	PN 630	14	M 22 x 1,5	21,0	27	10,0 x 2,0
VSM NW 13 VA	S	PN 400	16	M 24 x 1,5	22,0	30	12,0 x 2,0
VSM NW 16 VA	S	PN 400	20	M 30 x 2	26,5	36	16,0 x 2,5
VSM NW 20 VA	S	PN 400	25	M 36 x 2	27,5	46	20,0 x 2,5
VSM NW 25 VA	S	PN 400	30	M 42 x 2	28,5	50	25,0 x 2,5
VSM NW 32 VA	S	PN 315	38	M 52 x 2	32,5	60	33,3 x 2,4

PN = nazivni tlak PB = maks. obratovalni tlak - serija: LL = zelo lahko L = lahko S = težko - Ø = zunanji premer cevi

### Variante izdelka

VLM / VSM