

Lastnosti

Priključek 1	NPT-matični navoj (NPSM)
Oblika tesnila 1	60° zunanji konus
Priključek 2	notranji navoj NPT
Oblika tesnila 2	tesni navoje
Način izdelave	navojni cevni nastavek
Oblika izdelave	ravno
Material:	jeklo
Zaščita površine	galvanično prevlečeno

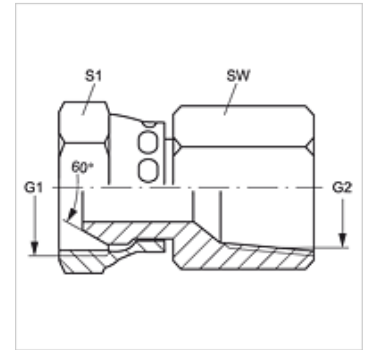

Artikel

Opis	G1	G2	SW (mm)	S1
G AN 02 IN	1/8" -27 NPT	1/8" -27 NPT	14	14
G AN 04 IN	1/4" -18 NPT	1/4" -18 NPT	18	18
G AN 06 IN	3/8" -18 NPT	3/8" -18 NPT	22	22
G AN 06 IN 04	3/8" -18 NPT	1/4" -18 NPT	22	22
G AN 08 IN 06	1/2" -14 NPT	3/8" -18 NPT	25	22
G AN 08 IN	1/2" -14 NPT	1/2" -14 NPT	25	25
G AN 08 IN 12	1/2" -14 NPT	3/4" -14 NPT	32	25
G AN 12 IN	3/4" -14 NPT	3/4" -14 NPT	32	32
G AN 16 IN	1" -11,5 NPT	1" -11,5 NPT	38	38
G AN 20 IN	1,1/4" -11,5 NPT	1,1/4" -11,5 NPT	48	48
G AN 24 IN	1,1/2" -11,5 NPT	1,1/2" -11,5 NPT	54	54
G AN 32 IN	2" -11,5 NPT	2" -11,5 NPT	67	67

SW, S1, S2 = ključna širina