

SRS 30-100 AL

Cevna objemka, težka izvedba

HANSA FLEX

Lastnosti

Način izdelave	enoceвна objemka
Način izdelave-dodatek	notranja stran objemke z rebri
Serijska	težko
Standard	DIN 3015-2
Temperatura min.	-40 °C
Temperatura max.	300 °C
Material:	aluminij

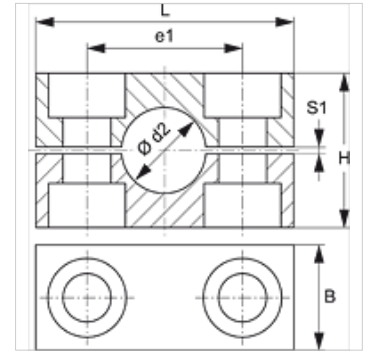

Opis

Rebra na notranji površini objemk dušijo udarce in vibracije in zmanjšujejo sile vzporedno z osjo cevi. Reza med obema polovicama ima za posledico prednapetje cevi.

Navodila za naročanje

1 kos = 2 polovici objemke

Artikel

Opis	Velikost objemke	Zunanji Ø cevi d2 (mm)	Zunanji Ø cevi d2	B (mm)	e1 (mm)	H (mm)	L (mm)	S1 (mm)
SRS 3006 AL	1	6,0	-	30	33	32	56	2
SRS 3008 AL	1	8,0	5/16"	30	33	32	56	2
SRS 3010 AL	1	10,0	-	30	33	32	56	2
SRS 3012 AL	1	12,0	-	30	33	32	56	2
SRS 3012.7 AL	1	12,7	1/2"	30	33	32	56	2
SRS 3013.5 AL	1	13,5	-	30	33	32	56	2
SRS 3014 AL	1	14,0	-	30	33	32	56	2
SRS 3015 AL	1	15,0	-	30	33	32	56	2
SRS 3016 AL	1	16,0	5/8"	30	33	32	56	2
SRS 3017.2 AL	1	17,2	-	30	33	32	56	2
SRS 3018 AL	1	18,0	-	30	33	32	56	2
SRS 4019 AL	2	19,0	3/4"	30	45	48	71	2
SRS 4020 AL	2	20,0	-	30	45	48	71	2
SRS 4021.3 AL	2	21,3	-	30	45	48	71	2
SRS 4022 AL	2	22,0	-	30	45	48	71	2
SRS 4023 AL	2	23,0	-	30	45	48	71	2
SRS 4025 AL	2	25,0	1"	30	45	48	71	2
SRS 4026.9 AL	2	26,9	-	30	45	48	71	2
SRS 4028 AL	2	28,0	-	30	45	48	71	2
SRS 4030 AL	2	30,0	-	30	45	48	71	2
SRS 5030 AL	3	30,0	-	30	60	60	86	2
SRS 5032 AL	3	32,0	1.1/4"	30	60	60	86	2
SRS 5033.7 AL	3	33,7	-	30	60	60	86	2
SRS 5035 AL	3	35,0	-	30	60	60	86	2
SRS 5038 AL	3	38,0	1.1/2"	30	60	60	86	2
SRS 5040 AL	3	40,0	-	30	60	60	86	2
SRS 5042 AL	3	42,0	-	30	60	60	86	2
SRS 6038 AL	4	38,0	1.1/2"	45	90	90	117	3
SRS 6040 AL	4	40,0	-	45	90	90	117	3
SRS 6042 AL	4	42,0	-	45	90	90	117	3
SRS 6045 AL	4	45,0	-	45	90	90	117	3
SRS 6048.3 AL	4	48,3	-	45	90	90	117	3
SRS 6050 AL	4	50,0	-	45	90	90	117	3
SRS 6051 AL	4	51,0	2"	45	90	90	117	3
SRS 6052 AL	4	52,0	-	45	90	90	117	3
SRS 6055 AL	4	55,0	-	45	90	90	117	3
SRS 6057 AL	4	57,0	2.1/4"	45	90	90	117	3
SRS 6060.3 AL	4	60,3	-	45	90	90	117	3
SRS 6063 AL	4	63,0	2.1/2"	45	90	90	117	3
SRS 6065 AL	4	65,0	-	45	90	90	117	3
SRS 6070 AL	4	70,0	-	45	90	90	117	3



Kljub skrbnemu preverjanju napak ne moremo izključiti in za informacije, ki so tu navedene, ne prevzemamo nobene odgovornosti.

11.02.2025

HANSA-FLEX AG

www.hansa-flex.com

1

SRS 30-100 AL

Cevna objemka, težka izvedba

HANSA FLEX

Artikel								
Opis	Velikost objemke	Zunanji Ø cevi d2 (mm)	Zunanji Ø cevi d2	B (mm)	e1 (mm)	H (mm)	L (mm)	S1 (mm)
SRS 7070 AL	5	70,0	-	60	122	120	154	5
SRS 7073 AL	5	73,0	-	60	122	120	154	5
SRS 7075 AL	5	75,0	-	60	122	120	154	5
SRS 7076.1 AL	5	76,1	3"	60	122	120	154	5
SRS 7080 AL	5	80,0	-	60	122	120	154	5
SRS 7082.5 AL	5	82,5	3.1/4"	60	122	120	154	5
SRS 7088.9 AL	5	88,9	3.1/2"	60	122	120	154	5
SRS 7090 AL	5	90,0	-	60	122	120	154	5
SRS 8090 AL	6	90,0	-	80	168	170	205	6
SRS 8100 AL	6	100,0	-	80	168	170	205	6
SRS 8101.6 AL	6	101,6	4"	80	168	170	205	6
SRS 8108 AL	6	108,0	4.1/4"	80	168	170	205	6
SRS 8114.3 AL	6	114,3	4.1/2"	80	168	170	205	6

Variante izdelka

SRS 30-100 PA	Cevna objemka, težka izvedba, notranja stran objemke z rebri
SRS 30-100 PP	Cevna objemka, težka izvedba, notranja stran objemke z rebri
SRS 30-100 PP G	Cevna objemka, težka izvedba, notranja stran objemke gladka
SRS 30-100 VG	Cevna objemka, težka izvedba, notranja stran objemke z rebri