

HK CSTS C

glava zgloba z ležajem za naknadno mazanje

HANSA FLEX

Lastnosti

Standard DIN 648, SERIJA E. TIP C

Območje uporabe Industrija

Material: jeklo ST 52.3

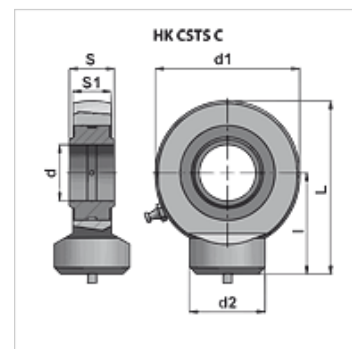
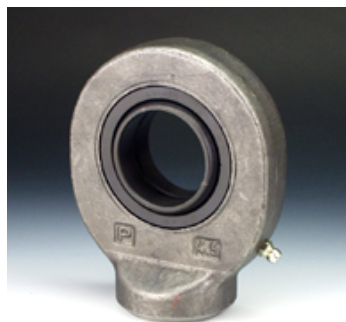

Navodilo

HKCSTS012C00 ni možno naknadno mazati

HKCSTS015C00, HKCSTS016C00, HKCSTS017C00 se mažejo le skozi luknjo za mazanje (ni mazalke)

Artikel

Opis	d (mm)	d1 (mm)	d2 (mm)	l (mm)	L (mm)	S1 (mm)	S (mm)	dovoljena din.obremenitev (kN)	Teža (kg)
HK CSTS 012 C 00	12	34	16,0	27	44,0	8	10	10	0,06
HK CSTS 015 C 00	15	40	20,0	31	51,0	10	12	17	0,12
HK CSTS 016 C 00	16	46	21,5	35	58,0	11	14	19	0,17
HK CSTS 017 C 00	17	46	22,5	35	58,0	11	14	21	0,18
HK CSTS 020 C 00	20	53	27,5	38	64,5	13	15	30	0,25
HK CSTS 025 C 00	25	64	33,5	45	77,0	17	20	48	0,45
HK CSTS 030 C 00	30	73	40,0	51	87,5	19	22	62	0,67
HK CSTS 035 C 00	35	82	47,0	61	102,0	21	25	80	0,98
HK CSTS 040 C 00	40	92	52,0	69	115,0	23	28	100	1,35
HK CSTS 045 C 00	45	102	58,0	77	128,0	27	32	127	1,93
HK CSTS 050 C 00	50	112	62,0	88	144,0	30	35	156	2,65
HK CSTS 060 C 00	60	135	70,0	100	167,5	38	44	245	4,60
HK CSTS 070 C 00	70	160	80,0	115	195,0	42	49	315	7,00
HK CSTS 080 C 00	80	180	95,0	141	231,0	47	55	400	11,00