

Lastnosti

Material: NBR

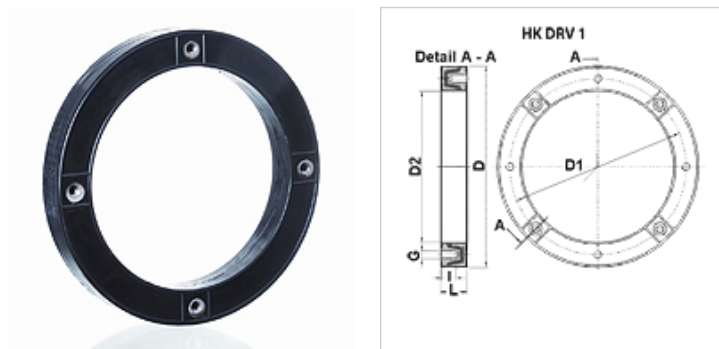

Opis

za uporabo med nosilcem črpalke in posodo
za znižanje ravni zvoka in dušenja nihanj
brez kovinskega stika med nadgradnjo in ogrodjem
Tesnenje posode z vulkaniziranim tesnilnim pasom

Artikel

Opis	IEC motor velikost	Ø D (mm)	Ø D1 (mm)	Ø D2 (mm)	G	l (mm)	L (mm)	Teža (kg)
HK DRV1 250	100L / 112M	250,0	215,0	191,0	4 x M12	22,0	45,0	1,67
HK DRV1 300	132S / 132M	300,0	265,0	235,0	4 x M12	22,0	50,0	2,54
HK DRV1 350	160M / 160L 180M / 180L	350,0	300,0	261,0	4 x M16	22,0	60,0	5,00
HK DRV1 400	200L	400,0	350,0	301,0	4 x M16	29,0	50,0	7,20