

WA VC

priključek ... VC, temprana litina

HANSA FLEX

Lastnosti

Območje uporabe Priključna armatura za kovinske cevi

Priključek 1 konični colski zunanji navoj

Oblika tesnila 1 konično tesnenje

Standard DIN EN 10226 / ISO 7-1

Uporaba lotana izvedba, obstojna do 200 °C

Oblika izdelave ravno

Izvedba 3-delni navoj

Material: temprana litina

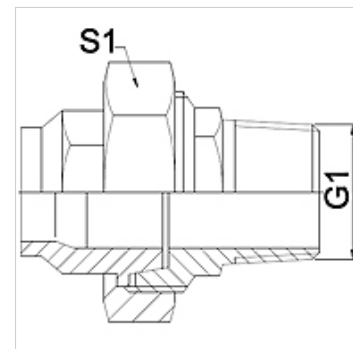

Navodilo

Navedene so orientacijske vrednosti!

The specified working pressure PN(bar) relates to the working temperature of -20 °C to 120 °C. At working temperature of 120 °C to 200 °C the working pressure PN (bar) reduces to 22,7 bar.

Navodila za naročanje

Druge izvedbe na zahtevo

Artikel

Opis	DN	PN (bar)	G1	S1 (mm)
WA 006 VC	6	25	R 1/4"	28,0
WA 010 VC	10	25	R 3/8"	32,0
WA 013 VC	13	25	R 1/2"	39,0
WA 020 VC	20	25	R 3/4"	48,0
WA 025 VC	25	25	R 1"	55,0
WA 032 VC	32	25	R 1.1/4"	67,0
WA 040 VC	40	25	R 1.1/2"	74,0
WA 050 VC	50	25	R 2"	90,0

Variante izdelka

WA VC RG priključek ... VC, rdeča litina, Rdeča litina

WA VC VA priključek ... VC, VA, nerjavno jeklo