

Lastnosti

Način izdelave	Usit obroč
Način izdelave-dodatek	samocentrirni
Material:	1) NBR 90 Shore A (2) Inox

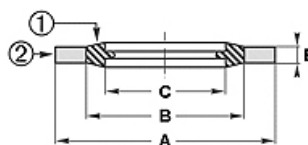

Toleranz / Tolerance				
Baureihe / Range	A	B	C	E
9; 92; 93	+0,13 0	+/-0,13	+/-0,13	+/-0,15

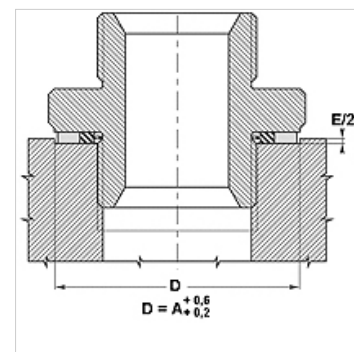

Artikel

Opis	za navoj	A (mm)	B (mm)	A (mm)	C (mm)	B (mm)	C (mm)	E (mm)	E (mm)	Tlak PB (bar)
08BS 9229 INOX-FKM	M 16	24,0	18,4	24,00	16,7	18,40	16,70	1,5	1,50	1400
UR 13.7-20-1.5 INOX-	-	13,7	20,0	-	1,5	-	-	-	-	-