

Lastnosti

Način izdelave	Krovna manšeta
Obratovalni tlak	do 500 bar
Drsna hitrost max.	0,5 m/s
Temperatura min.	-30 °C
Temperatura max.	110 °C
Sredstva	Mineralna olja vodne emulzije
Montaža	na večdelnih batih
Uporaba	Hidravlika

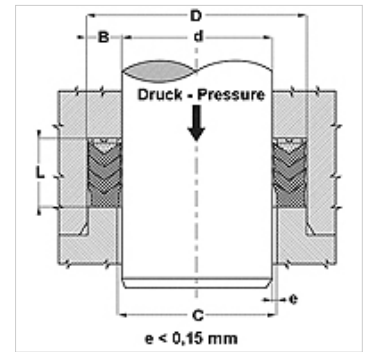
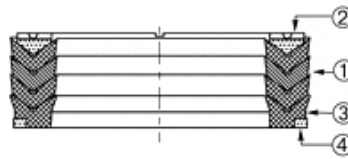

Artikel

Opis	d (mm)	D (mm)	L (mm)
CH-375 325-NEO	82,55	95,25	21,72
CH-425 350-NEO	88,90	107,95	31,00
CH-450 350-NEO	88,90	114,30	35,32
CH-450 375-NEO	95,25	114,30	25,40
CH-450 387-NEO	98,42	114,42	26,59
CH-500 425-NEO	107,95	127,00	30,00
CH-550 450-1-NEO	114,30	139,70	33,50
CH-551 452-NEO	115,00	140,00	37,12
CH-590 472-NEO	120,00	150,00	44,00
CH-600 500-NEO	127,00	152,40	38,63
CH-629 511-1-NEO	130,00	160,00	43,50
CH-826 708-B-NEO	180,00	210,00	32,97
CH-875 750-NEO	190,50	222,25	50,00
CH-110 2984B-NEO	250,00	280,00	32,97

BD = obratovalni tlak