

CH1

Krovna manšeta, CH1

Lastnosti

Način izdelave	Krovna manšeta batnice
Obratovalni tlak	do 400 bar
Drzna hitrost max.	0,5 m/s
Temperatura min.	-30 °C
Temperatura max.	110 °C
Sredstva	Mineralna olja vodne emulzije
Montaža	v odprtih utorih B
Material:	Tlačni obroč: s trdo tkanino ojačani NBR (2) Krovna manšeta: 2 x NBR + 3 x s tkanino ojačani NBR (3) Tlačni obroč: s trdo tkanino ojačani NBR
Uporaba	Hidravlika



Toleranz / Tolerance		
d	D	L
H8 / F7	H9	d < 200 : Lj +1,0 / 1,5 d > 200 : Lj +1,5 / 2,0

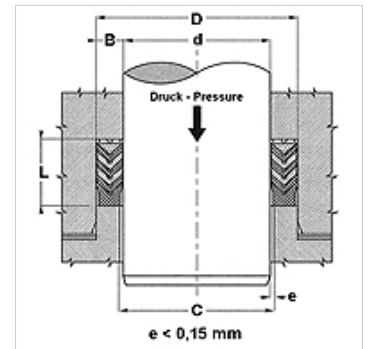

Opis

visoka temperaturna odpornost
za težke delovne pogoje, kot so tlačni udari
močna nihanja, slabe površine.

Navodila za naročanje

Druge mere na zahtevo

V primeru posebnih delovnih pogojev (tekočina, temperatura, tlak ...) nas, prosimo, pokličite.

Drug možni material: FPM.

Artikel

Opis	d (mm)	D (mm)	L (mm)
CH1-008	8,00	18,0	18,5
CH1-010	10,00	20,0	18,5
CH1-012	12,00	22,0	18,5
CH1-014	14,00	24,0	18,5
CH1-015	15,00	25,0	18,5
CH1-016	16,00	26,0	18,5
CH1-018	18,00	28,0	18,5
CH1-020	20,00	30,0	18,5
CH1-022	22,00	32,0	18,5
CH1-025	25,00	37,0	22,5
CH1-028	28,00	40,0	22,5
CH1-030	30,00	42,0	22,5
CH1-032	32,00	44,0	22,5
CH1-035	35,00	47,0	22,5
CH1-036	36,00	48,0	22,5
CH1-040	40,00	52,0	22,5
CH1-042	42,00	54,0	22,5
CH1-045	45,00	60,0	22,5
CH1-048	48,00	63,0	22,5
CH1-050	50,00	65,0	22,5
CH1-055	55,00	70,0	22,5
CH1-056	56,00	71,0	22,5
CH1-060	60,00	75,0	22,5
CH1-063	63,00	78,0	22,5
CH1-065	65,00	80,0	22,5
CH1-070	70,00	85,0	22,5
CH1-075	75,00	90,0	22,5
CH1-080	80,00	95,0	22,5
CH1-085	85,00	100,0	22,5
CH1-090	90,00	105,0	22,5
CH1-100	100,00	115,0	30,0
CH1-110	110,00	125,0	30,0
CH1-115	115,00	130,0	30,0
CH1-125	125,00	140,0	34,0



CH1

Krovna manšeta, CH1

Artikel

Opis	d (mm)	D (mm)	L (mm)
CH1-140	140,00	155,0	34,0
CH1-150	150,00	170,0	40,0
CH1-160	160,00	180,0	40,0
CH1-180	180,00	200,0	40,0
CH1-200	200,00	220,0	40,0