

Lastnosti

Način izdelave	Krovna manšeta batnice
Obratovalni tlak	do 500 bar
Drzna hitrost max.	0,5 m/s
Temperatura min.	-30 °C
Temperatura max.	110 °C
Sredstva	Mineralna olja vodne emulzije
Montaža	v odprtih utorih
Material:	(1) Tlačni obroč: s trdo tkanino ojačani NBR (2) Krovna manšeta: 2 x NBR + 3 x s tkanino ojačani NBR (3) Podporni obroč: acetatna smola / PTBR
Uporaba	Hidravlika

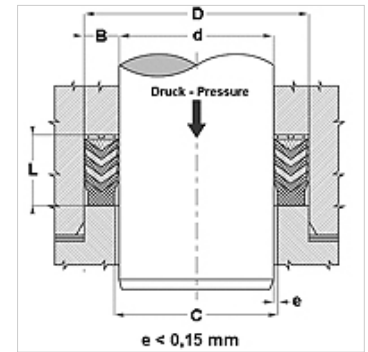

Toleranz / Tolerance		
d	D	L
H8 / F7	H9	d < 200 : Lj +1,0 / 1,5 d > 200 : Lj +1,5 / 2,0



Opis

visoka temperaturna odpornost
za težke delovne pogoje, kot so tlačni udari
močna nihanja, slabe površine.

Navodila za naročanje

Druge mere na zahtevo

V primeru posebnih delovnih pogojev (tekočina, temperatura, tlak ...) nas, prosimo, pokličite.

Drug možni material: FPM.

Artikel

Opis	d (mm)	D (mm)	L (mm)
CH2-020	20,00	32,0	22,5
CH2-022	22,00	34,0	22,5
CH2-025	25,00	40,0	22,5
CH2-028	28,00	43,0	22,5
CH2-030	30,00	45,0	22,5
CH2-032	32,00	47,0	22,5
CH2-035	35,00	50,0	22,5
CH2-036	36,00	51,0	22,5
CH2-040	40,00	55,0	22,5
CH2-042	42,00	57,0	22,5
CH2-045	45,00	65,0	27,5
CH2-050	50,00	70,0	30,0
CH2-055	55,00	75,0	30,0
CH2-056	56,00	76,0	37,0
CH2-060	60,00	80,0	37,0
CH2-063	63,00	83,0	37,0
CH2-065	65,00	85,0	40,0
CH2-070	70,00	90,0	40,0
CH2-075	75,00	95,0	40,0
CH2-080	80,00	100,0	40,0
CH2-090	90,00	110,0	40,0
CH2-100	100,00	120,0	40,0
CH2-110	110,00	130,0	40,0
CH2-120	120,00	145,0	50,0
CH2-125	125,00	150,0	46,0
CH2-140	140,00	165,0	46,0
CH2-160	160,00	190,0	60,0
CH2-180	180,00	210,0	60,0
CH2-200	200,00	230,0	60,0