

DSR U FPM

Dvojno strgalo, DSR-U-FPM

HANSA FLEX

Lastnosti

Način izdelave	Strgalo
Drсна hitrost max.	0,5 m/s
Temperatura min.	-30 °C
Temperatura max.	110 °C
Sredstva	Mineralna olja vodne emulzije
Montaža	strgalo ukrivite v obliki ledvice in ga vtisnite v utor
Uporaba	Hidravlika
Material:	FPM



Toleranz / Tolerance					
d	D	L	C	F	G
h11	H11	+0,20 0	H10	H11	+0,20 0

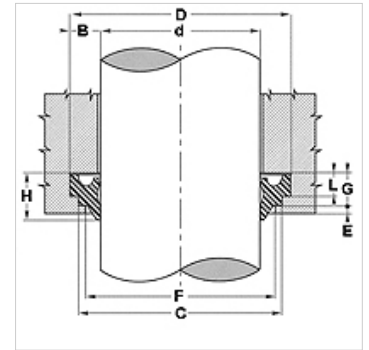

Opis

enostavna montaža

Artikel

Opis	D (mm)	d (mm)	E (mm)	L (mm)	C (mm)
DSR 56-U FPM	64	56	1,0	4,0	62