

## Lastnosti

<b>Način izdelave</b>	Strgalo
<b>Drсна hitrost max.</b>	0,5 m/s
<b>Temperatura min.</b>	-20 °C
<b>Temperatura max.</b>	200 °C
<b>Sredstva</b>	Mineralna olja vodne emulzije
<b>Montaža</b>	vtisne se v odprt utor
<b>Material:</b>	(1) Puša: jeklo Strgalo: FPM
<b>Uporaba</b>	Hidravlika

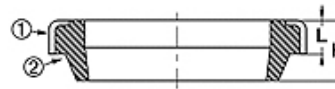

Toleranz / Tolerance		
d	D	L
h11	H8	+0,20 0

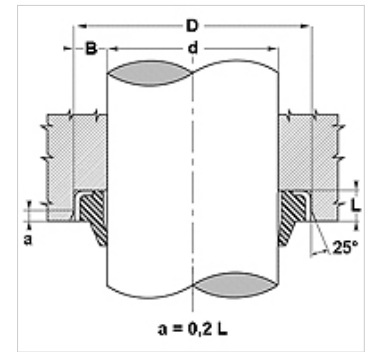

## Opis

potrebuje malo prostora  
nesnaga ne more prodreti skozi zunanji kovinski obroč.  
enostavna rešitev.

## Navodila za naročanje

V primeru posebnih delovnih pogojev (tekočina, temperatura, tlak ...) nas, prosimo, pokličite.

## Artikel

Opis	d (mm)	D (mm)	L (mm)	H (mm)
GA 16 22-3 FPM	16	22	3,0	4
GA 25 35-7 FPM	25	35	7,0	10
GA 30 40-7 FPM	30	40	7,0	10
GA 32 45-4 FPM	32	45	4,0	8
GA 45 55-7 FPM	45	55	7,0	10
GA 45 60-7 FPM	45	60	7,0	10
GA 50 56-5 FPM	50	56	5,0	8
GA 60 70-7 FPM	60	70	7,0	10
GA 63 75-7 FPM	63	75	7,0	10
GA 70 80-7 FPM	70	80	7,0	10