

Lastnosti

Drсна hitrost max.	1,0 m/s
Tlačna trdnost po DIN 53454 (N/mm²)	350 N/mm ²
Površinski pritisk	50 N/mm ²
Temperatura min.	-40 °C
Temperatura max.	130 °C
Sredstva	Mineralna olja vodne emulzije
Montaža	vstavite v utor
Material:	Vodilni obroč: Laminat iz poliestrske smole s tkanino iz sintetičnih vlaken z grafitom

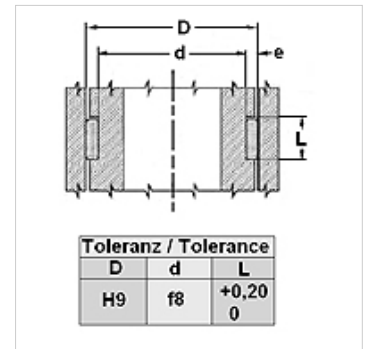

Schnittmöglichkeiten / Cutting options



Toleranz / Tolerance

D	d	L
H9	f8	+0,20 0

Navodilo

Izračun prečne sile; $F = p \times D \times L \times n$

F= maksimalna prečna sila (N)

p= maksimalno ploskovni pritisk (N/mm²)

D x L= projicirana površina (mm²)

n= število obročev

Opis

možnost dobave kot metrsko blago.

enostavna obdelava vgradnega utora in montaža

majhen koeficient trenja.

visoka nosilnost

Navodila za naročanje

V primeru posebnih delovnih pogojev (tekočina, temperatura, tlak ...) nas, prosimo, pokličite.

Artikel

Opis	e (mm)	L (mm)
GTH 25 056	2,5	5,6
GTH 25 097	2,5	9,7
GTH 25 150	2,5	15,0
GTH 25 200	2,5	20,0
GTH 25 250	2,5	25,0
GTH 30 097	3,0	9,7
GTH 30 128	3,0	12,8
GTH 30 150	3,0	15,0
GTH 30 192	3,0	19,2
GTH 30 200	3,0	20,0
GTH 30 250	3,0	25,0
GTH 30 300	3,0	30,0
GTH 35 300	3,5	30,0
GTH 40 097	4,0	9,7
GTH 40 128	4,0	12,8
GTH 40 150	4,0	15,0
GTH 40 200	4,0	20,0
GTH 40 250	4,0	25,0