

## Lastnosti

Način izdelave	Vodilni obroč
Drсна hitrost max.	1,0 m/s
Tlačna trdnost po DIN 53454 (N/mm <sup>2</sup> )	270 N/mm <sup>2</sup>
Površinski pritisk	35 N/mm <sup>2</sup>
Temperatura min.	-40 °C
Temperatura max.	120 °C
Sredstva	Mineralna olja
Montaža	vstavite v utór
Material:	Fenolna smola z bombažno tkanino

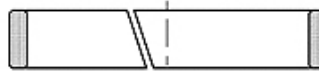

Toleranz / Tolerance		
d	D	L
f7	H9	+0,20 0

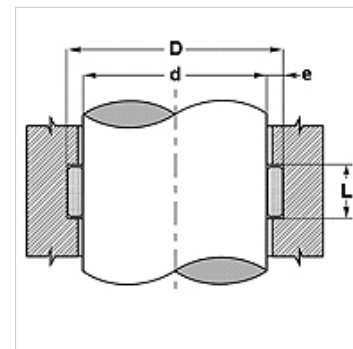

## Navodilo

Izračun prečne sile;  $F = p \times D \times L \times n$

F= maksimalna prečna sila (N)

p= maksimalno ploskovni pritisk (N/mm<sup>2</sup>)

D x L= projicirana površina (mm<sup>2</sup>)

n= število obročev

## Opis

enostavna obdelava vgradnega utora in montaža

majhen koeficient trenja.

visoka nosilnost

## Artikel

Opis	D (mm)	d (mm)	L (mm)
IGTP 250 560 280 A	33	28	5,6
IGTP 250 970 550 A	60	55	9,7
IGTP 251 300 600 A	65	60	13,0
IGTP 251 500 500 A	55	50	15,0
IGTP 251 500 700 A	75	70	15,0
IGTP 251 500 800 A	85	80	15,0
IGTP 251 500 850 A	90	85	15,0
IGTP 251 500 900 A	95	90	15,0
IGTP 251 501 150 A	120	115	15,0
IGTP 251 520 700 A	75	70	15,2
IGTP 251 520 800 A	85	80	15,2
IGTP 251 520 900 A	95	90	15,2
IGTP 251 521 200 A	125	120	15,2
IGTP 251 600 650 A	70	65	16,0
IGTP 251 600 700 A	75	70	16,0
IGTP 251 600 800 A	85	80	16,0
IGTP 255 020 700 A	75	70	50,2
IGTP 255 020 800 A	85	80	50,2
IGTP 255 020 900 A	95	90	50,2
IGTP 256 021 000 A	105	100	60,2
IGTP 256 521 100 A	115	110	65,2
IGTP 257 021 200 A	125	120	70,2
IGTP 125 150 1500 A	155	150	15,0