

Lastnosti

Način izdelave	Strgalo
Drсна hitrost max.	0,5 m/s
Temperatura min.	-30 °C
Temperatura max.	80 °C
Sredstva	Mineralna olja
Montaža	vtisne se v odprt utor
Izvedba	Palec
Material:	(1) Puša: jeklo (2) Strgalo: PUR
Uporaba	Hidravlika

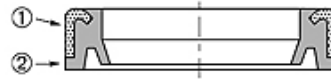

Toleranz / Tolerance		
d	D	L
h11	H8	+0,20 0

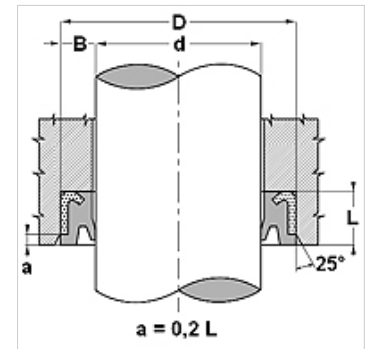

Opis

potrebuje malo prostora
visoka obrabna odpornost
za gradbene stroje in težke delovne pogoje

Artikel

Opis	d (mm)	D (mm)	L (mm)
SWP-I 075 125	19,05	31,75	6,30
SWP-I 100 150	25,40	38,10	8,00
SWP-I 112 162	28,57	41,27	8,00
SWP-I 125 175	31,75	44,45	6,30
SWP-I 137 187	34,92	47,62	8,00
SWP-I 150 187	38,10	47,62	6,30
SWP-I 150 200	38,10	50,80	6,30
SWP-I 150 225	38,10	57,15	9,50
SWP-I 162 212	41,27	53,97	6,30
SWP-I 175 225	44,45	57,15	6,30
SWP-I 175 212	44,45	53,90	4,80
SWP-I 200 250	50,80	63,50	7,93
SWP-I 200 262	50,80	66,67	6,30
SWP-I 200 275	50,80	69,85	9,50
SWP-I 225 275	57,15	69,85	6,30
SWP-I 225 287	57,15	73,02	6,30
SWP-I 250 300	63,50	76,20	7,92
SWP-I 250 325	63,50	82,55	9,50
SWP-I 275 325	69,82	82,55	8,00
SWP-I 275 375	69,85	95,25	12,70
SWP-I 300 350	76,20	88,90	7,92
SWP-I 325 375-1	82,55	95,25	7,92
SWP-I 325 375	82,55	95,25	9,50
SWP-I 325 425	82,55	107,95	12,70
SWP-I 350 450	88,90	114,30	12,70