

Lastnosti

Način izdelave	Utorni obroč batnice
Obratovalni tlak	do 500 bar
Drсна hitrost max.	0,5 m/s
Temperatura min.	-30 °C
Temperatura max.	80 °C
Sredstva	Mineralna olja
Montaža	v zaprtih utorih A v odprtih utorih B
Material:	(1) Tesnilo: PUR (2) Podporni obroč: acetatna smola / PTBR
Uporaba	Hidravlika

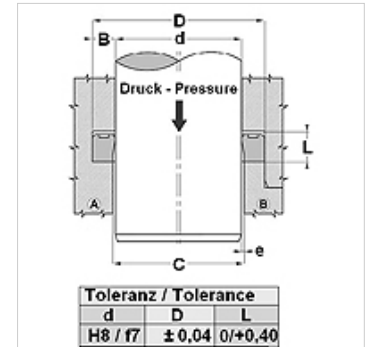

Druck bar	Spaltmaß / Clearance			
	e (mm)			
	TS-TS...L		TS...-AI-TS...-LA	
	d<60mm	d>60mm	d<60mm	d>60mm
50	<0,40	<0,50	<0,60	<0,80
100	<0,30	<0,40	<0,60	<0,80
200	<0,20	<0,30	<0,40	<0,60
300	<0,15	<0,20	<0,30	<0,40
400	<0,10	<0,15	<0,20	<0,30
500			<0,10	<0,15



Toleranz / Tolerance		
d	D	L
H8 / f7	± 0,04	0/+0,40

Opis

visoka obrabna odpornost
zelo dobro tesnenje pri nizkem tlaku.
Hitre spremembe obremenitve.

Navodila za naročanje

Tesnila s premerom od 20 do 510 mm lahko izdelamo hitro.

Artikel

Opis	d (mm)	D (mm)	L (mm)
TS 40 48-LA	40	48	9,0
TS 40 50-LA1	40	50	11,0
TS 40 52-LA	40	52	11,0
TS 40 55-LA	40	55	8,5
TS 40 55-LA1	40	55	11,0
TS 45 55-LA1	45	55	11,0
TS 45 60-LA	45	60	11,0
TS 50 60-LA1	50	60	11,0
TS 50 65-LA	50	65	11,0
TS 55 65-LA1	55	65	11,0
TS 56 71-LA	56	71	12,5
TS 60 70-LA4	60	70	13,5
TS 60 75-LA	60	75	13,0
TS 60 80-LA	60	80	13,0
TS 63 75-LA	63	75	13,0
TS 63 78-LA1	63	78	12,5
TS 63 78-LA	63	78	13,5
TS 63 83-LA	63	83	13,0
TS 65 75-LA	65	75	13,0
TS 65 80-LA	65	80	12,5
TS 70 85-LA1	70	85	13,0
TS 75 90-LA	75	90	13,0
TS 75 95-LA	75	95	14,5
TS 80 88-LA	80	88	10,0
TS 80 95-LA	80	95	12,5
TS 80 96-LA	80	96	10,5
TS 80 100-LA	80	100	12,5
TS80 100-LA1	80	100	14,5
TS 90 105-LA2	90	105	9,5
TS 90 105-LA1	90	105	13,0
TS 90 110-LA	90	110	13,0
TS 95 115-LA	95	115	14,5
TS 100 110-LA	100	110	13,5
TS 100 113-LA	100	113	13,5
TS 100 120-LA	100	120	14,5
TS 110 120-LA	110	120	14,5
TS 110 125-LA1	110	125	13,0
TS 120 140-LA	120	140	12,5



TS LA

Tesnilo batnice, TS-LA

Artikel

Opis	d (mm)	D (mm)	L (mm)
TS 140 165-LA	140	165	19,0