

Lastnosti

Način izdelave	Komplet bata
Uporaba	Hidravlika

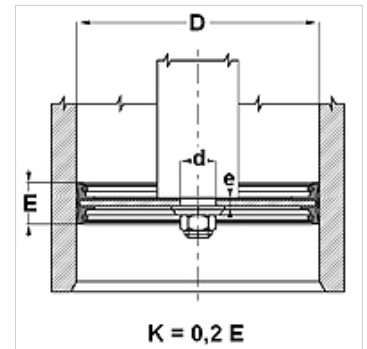

Toleranz / Tolerance		
D	d	E
H11	f8	$\pm 0,50$



Artikel

Opis	D (mm)	d (mm)	P (mm)	E (mm)	e (mm)
TDO 080 FPM	80	12,2	54	30	5,0
TDO 100 FPM	100	12,2	72	35	6,0