

Lastnosti

Način izdelave	Strgalo
Drсна hitrost max.	4,0 m/s
Temperatura min.	-40 °C
Temperatura max.	110 °C
Sredstva	mineralno olje
Montaža	strgalo ukrivite v obliki ledvice in ga vtisnite v utor
Uporaba	For the usage at higher pollution, for e.g.: Mining foundries
Material:	PU 93° Shore A

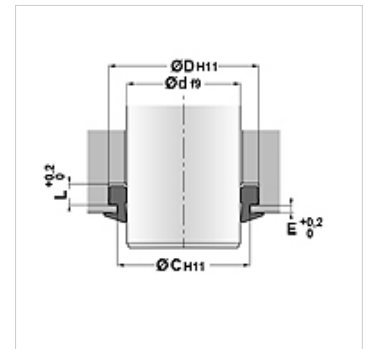
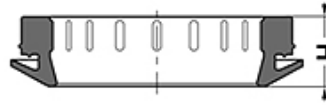

Artikel

Opis	C (mm)	D (mm)	d (mm)	E (mm)	H (mm)	L (mm)
WAH-35	42,0	45,0	35	1,5	10,0	6,3
WAH-36	41,5	44,0	36	1,5	8,0	5,0
WAH-40	45,5	48,0	40	1,5	8,0	5,0
WAH-45	50,5	53,0	45	1,5	8,0	5,0
WAH-50	55,5	58,0	50	1,5	8,0	5,0
WAH-56	63,0	66,0	56	1,5	10,0	6,3
WAH-60	67,0	70,0	60	1,5	10,0	6,3
WAH-63	70,0	73,0	63	1,5	10,0	6,3
WAH-70	78,4	82,6	70	2,0	12,0	8,0
WAH-80	87,0	90,0	80	1,5	10,0	6,3
WAH-90	96,0	102,2	90	2,8	12,4	7,1