

Osobine

| | |
|--------------------|--------------------|
| Konstrukcija | Rezni prsten |
| Norma | DIN 3861 oblik B |
| Materijal | čelik |
| Površinska zaštita | galvanska prevlaka |

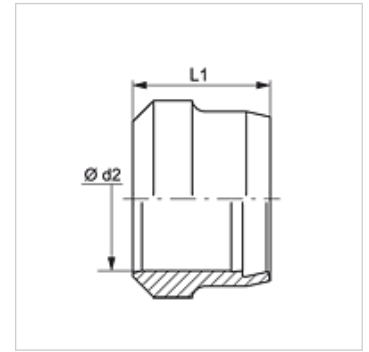
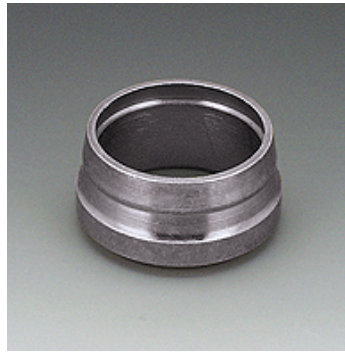

Napomena

Molimo Vas da napomene za montažu, ugradnju, opterećenje pod pritiskom i dozvoljene radne temperature nađete u tehničkim informacijama o navojnim spojevima za cevi.

Artikal

| Naziv | Seriya | Ø d2 (mm) | L1 (mm) |
|-----------|--------|--------------|------------|
| SRD 04 LL | LL | 4 | 6,0 |
| SRD 05 LL | LL | 5 | 7,0 |
| SRD 06 LL | LL | 6 | 7,0 |
| SRD 08 LL | LL | 8 | 7,0 |
| SRD 10 LL | LL | 10 | 7,0 |
| SRD 12 LL | LL | 12 | 7,5 |
| SRD 16 LL | LL | 16 | 9,0 |
| SRD 06 | L / S | 6 | 9,5 |
| SRD 08 | L / S | 8 | 9,5 |
| SRD 10 | L / S | 10 | 10,0 |
| SRD 12 | L / S | 12 | 10,0 |
| SRD 14 | S | 14 | 10,5 |
| SRD 15 | L | 15 | 10,0 |
| SRD 16 | S | 16 | 10,5 |
| SRD 18 | L | 18 | 10,0 |
| SRD 20 | S | 20 | 12,5 |
| SRD 22 | L | 22 | 11,5 |
| SRD 25 | S | 25 | 12,5 |
| SRD 28 | L | 28 | 11,5 |
| SRD 30 | S | 30 | 13,5 |
| SRD 35 | L | 35 | 13,5 |
| SRD 38 | S | 38 | 13,5 |
| SRD 42 | L | 42 | 13,5 |
| SRD 65 | L | 65 | 21,2 |

Seriya: LL = veoma lako L = lako S = teško - PN = nominalni pritisak PB = maks. radni pritisak - Ø d2 = spoljni prečnik cevi

Varijante proizvoda

| | |
|--------|-------------------------------|
| SRD MG | Rezni prsten, Mesing |
| SRD VA | Rezni prsten, plemeniti čelik |