

SRD MG

Rezni prsten

Osobine

Konstrukcija	Rezni prsten
Norma	DIN 3861
Materijal	Mesing

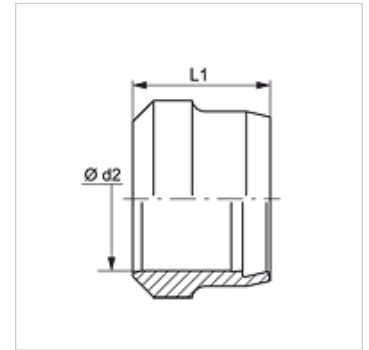

Napomena

Molimo Vas da napomene za montažu, ugradnju, opterećenje pod pritiskom i dozvoljene radne temperature nađete u tehničkim informacijama o navojnim spojevima za cevi.

Artikal

Naziv	Seriya	Ø d2 (mm)	L1 (mm)
SRD 04 LL MG	LL	4	6,0
SRD 05 LL MG	LL	5	7,0
SRD 06 LL MG	LL	6	7,0
SRD 08 LL MG	LL	8	7,0
SRD 10 LL MG	LL	10	7,0
SRD 12 LL MG	LL	12	7,5
SRD 06 MG	L / S	6	9,5
SRD 08 MG	L / S	8	9,5
SRD 10 MG	L / S	10	10,0
SRD 12 MG	L / S	12	10,0
SRD 14 MG	S	14	10,0
SRD 15 MG	L	15	10,0
SRD 16 MG	S	16	10,5
SRD 18 MG	L	18	10,0
SRD 20 MG	S	20	12,5
SRD 22 MG	L	22	10,5
SRD 25 MG	S	25	12,5
SRD 28 MG	L	28	10,5
SRD 30 MG	S	30	13,0
SRD 35 MG	L	35	13,0
SRD 38 MG	S	38	13,5
SRD 42 MG	L	42	13,0

Seriya: LL = veoma lako L = lako S = teško - PN = nominalni pritisak PB = maks. radni pritisak - Ø d2 = spoljni prečnik cevi

Varijante proizvoda

SRD	Rezni prsten, čelik
SRD VA	Rezni prsten, plemeniti čelik