

### Osobine

Priključak 1	metrički spoljni cilindrični navoj
Oblik zaptivke 1	24° unutrašnji konus
Priključak 2	metrički spoljni cilindrični navoj
Oblik zaptivke 2	24° unutrašnji konus
Konstrukcija	Zglobni navojni spoj
Dodatak za vrstu konstrukciju	Kuglični ležaj
Konstrukcija	pravo
Obim isporuke	Nastavak (bez preklopne navrtke i reznog prstena)
Materijal	čelik
Površinska zaštita	galvanska prevlaka

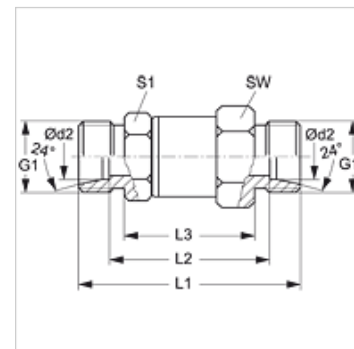

### Napomena

Molimo Vas da napomene za montažu, ugradnju, opterećenje pod pritiskom i dozvoljene radne temperature nađete u tehničkim informacijama o navojnim spojevima za cevi.

### Artikal

Naziv	Seriya	Radni pritisak bar	Ø d2 (mm)	G1	L1 (mm)	L2 (mm)	L3 (mm)	SW (mm)	S1
DG NW 04 HL	L	PN 315	6	M 12 x 1,5	57,0	43,0	37,0	22	19
DG NW 06 HL	L	PN 315	8	M 14 x 1,5	57,0	43,0	37,0	22	19
DG NW 08 HL	L	PN 315	10	M 16 x 1,5	68,0	54,0	46,0	30	24
DG NW 10 HL	L	PN 315	12	M 18 x 1,5	68,0	54,0	46,0	30	24
DG NW 13 HL	L	PN 315	15	M 22 x 1,5	70,0	56,0	46,0	30	24
DG NW 16 HL	L	PN 315	18	M 26 x 1,5	80,5	65,5	56,5	41	36
DG NW 20 HL	L	PN 160	22	M 30 x 2	84,5	69,5	56,5	41	36
DG NW 25 HL	L	PN 160	28	M 36 x 2	96,5	81,5	68,5	60	55
DG NW 32 HL	L	PN 160	35	M 45 x 2	100,5	79,5	68,5	60	55
DG NW 03 HS H	S	PN 500	6	M 14 x 1,5	61,0	47,0	37,0	22	19
DG NW 04 HS H	S	PN 500	8	M 16 x 1,5	61,0	47,0	37,0	22	19
DG NW 06 HS H	S	PN 500	10	M 18 x 1,5	61,0	55,0	37,0	30	24
DG NW 08 HS H	S	PN 500	12	M 20 x 1,5	72,0	57,0	48,0	30	24
DG NW 10 HS H	S	PN 500	14	M 22 x 1,5	73,0	57,0	45,0	30	24
DG NW 13 HS H	S	PN 400	16	M 24 x 1,5	74,0	57,0	46,0	30	24
DG NW 16 HS H	S	PN 400	20	M 30 x 2	92,0	71,0	60,0	41	36
DG NW 20 HS H	S	PN 400	25	M 36 x 2	98,0	72,0	62,0	41	36
DG NW 25 HS H	S	PN 400	30	M 42 x 2	109,0	82,0	69,0	60	55
DG NW 32 HS H	S	PN 315	38	M 52 x 2	114,0	82,0	70,0	60	55

Seriya: LL = veoma lako L = lako S = teško - PN = nominalni pritisak PB = maks. radni pritisak - Ø d2 = spoljni prečnik cevi