

Osobine

Priključak 1	metrički spoljni konusni navoj
Oblik zaptivke 1	zaptivanje preko navoja
Priključak 2	metrički spoljni cilindrični navoj
Oblik zaptivke 2	24° unutrašnji konus
Konstrukcija	Uvrtni navojni spoj
Konstrukcija	pravo
Norma	DIN 2353 ISO 8434-1
Obim isporuke	Nastavak (bez preklopne navrtke i reznog prstena)
Materijal	čelik
Površinska zaštita	galvanska prevlaka

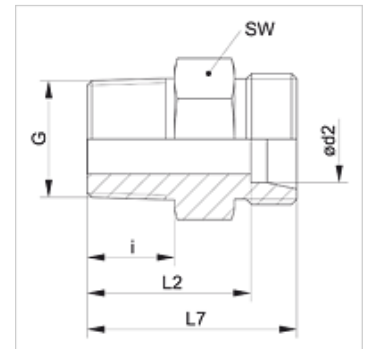

Napomena

Molimo Vas da napomene za montažu, ugradnju, opterećenje pod pritiskom i dozvoljene radne temperature nađete u tehničkim informacijama o navojnim spojevima za cevi.

Artikal

Naziv	Serija	Radni pritisak bar	Ø d2 (mm)	G	i (mm)	L2 (mm)	L7 (mm)	SW (mm)
XVM 04 LL 6	LL	PN 100	4	M 6 x 1 K	8	16,0	20	9
XVM 04 LL	LL	PN 100	4	M 8 x 1 K	8	16,0	20	9
XVM 04 LL 10	LL	PN 100	4	M 10 x 1 K	8	16,0	20	11
XVM 05 LL	LL	PN 100	5	M 8 x 1 K	8	14,5	20	11
XVM 06 LL 6	LL	PN 100	6	M 6 x 1 K	8	14,5	20	11
XVM 06 LL 8	LL	PN 100	6	M 8 x 1 K	8	14,5	20	11
XVM 06 LL	LL	PN 100	6	M 10 x 1 K	8	14,5	20	11
XVM 08 LL	LL	PN 100	8	M 10 x 1 K	8	16,5	22	12
XVM 12 LL	LL	PN 100	12	M 16 x 1,5 K	12	21,0	27	19
XVMK NW 04 HL	L	PN 315	6	M 10 x 1 K	8	15,0	22	12
XVMK NW 06 HL	L	PN 315	8	M 12 x 1,5 K	12	20,0	27	14
XVMK NW 08 HL	L	PN 315	10	M 14 x 1,5 K	12	21,0	28	17
XVMK NW 10 HL	L	PN 315	12	M 16 x 1,5 K	12	22,0	29	19
XVMK NW 13 HL	L	PN 315	15	M 18 x 1,5 K	12	23,0	30	24
XVMK NW 16 HL	L	PN 315	18	M 22 x 1,5 K	14	25,5	33	27
XVMK NW 20 HL	L	PN 160	22	M 26 x 1,5 k	18	31,5	39	32
XVMK NW 25 HL	L	PN 160	28	M 33 x 2 K	20	34,5	42	41
XVMK NW 32 HL	L	PN 160	35	M 42 x 2 K	21	35,5	46	46
XVMK NW 40 HL	L	PN 160	42	M 48 x 2 K	22	38,0	49	55
XVMK NW 03 HS	S	PN 630	6	M 12 x 1,5 K	12	24,0	31	14

Serija: LL = veoma lako L = lako S = teško - PN = nominalni pritisak PB = maks. radni pritisak - Ø d2 = spoljni prečnik cevi

Varijante proizvoda

XVMK VA	Uvrtni navojni spoj, plemeniti čelik
VMK	Uvrtni navojni spoj, čelik