

Osobine

Priključak 1	metrički navoj navrtke
Oblik zaptivke 1	24° spoljašnji konus sa O-prstenom
Konstrukcija	Navrtka za zatvaranje
Konstrukcija	pravo
Norma	DIN 2353 ISO 8434-1
Materijal	čelik
Površinska zaštita	galvanska prevlaka

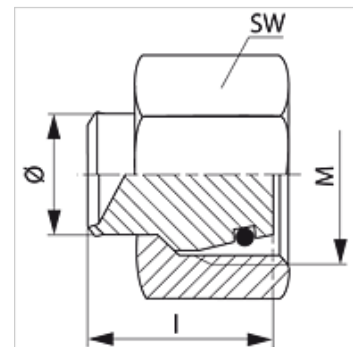

Napomena

Molimo Vas da napomene za montažu, ugradnju, opterećenje pod pritiskom i dozvoljene radne temperature nađete u tehničkim informacijama o navojnim spojevima za cevi.

Artikal

Naziv	Seriya	Radni pritisak bar	Cev spolja Ø (mm)	M	I (mm)	SW (mm)	OR
VLM NW 04	L	PN 400	6	M 12 x 1,5	18,5	14	4,0 x 1,5
VLM NW 06	L	PN 400	8	M 14 x 1,5	18,0	17	6,0 x 1,5
VLM NW 08	L	PN 400	10	M 16 x 1,5	19,5	19	7,5 x 1,5
VLM NW 10	L	PN 400	12	M 18 x 1,5	19,0	22	9,0 x 1,5
VLM NW 13	L	PN 400	15	M 22 x 1,5	19,0	27	12,0 x 2,0
VLM NW 16	L	PN 315	18	M 26 x 1,5	22,0	32	15,0 x 2,0
VLM NW 20	L	PN 315	22	M 30 x 2	22,0	36	20,0 x 2,0
VLM NW 25	L	PN 250	28	M 36 x 2	23,5	41	26,0 x 2,0
VLM NW 32	L	PN 250	35	M 45 x 2	27,0	50	32,0 x 2,5
VLM NW 40	L	PN 250	42	M 52 x 2	27,5	60	38,0 x 2,5
VSM NW 03	S	PN 630	6	M 14 x 1,5	18,5	17	4,0 x 1,5
VSM NW 04	S	PN 630	8	M 16 x 1,5	18,0	19	6,0 x 1,5
VSM NW 06	S	PN 630	10	M 18 x 1,5	19,5	22	7,5 x 1,5
VSM NW 08	S	PN 630	12	M 20 x 1,5	19,0	24	9,0 x 1,5
VSM NW 10	S	PN 630	14	M 22 x 1,5	21,0	27	10,0 x 2,0
VSM NW 13	S	PN 400	16	M 24 x 1,5	22,0	30	12,0 x 2,0
VSM NW 16	S	PN 400	20	M 30 x 2	26,5	36	16,0 x 2,5
VSM NW 20	S	PN 400	25	M 36 x 2	27,5	46	20,0 x 2,5
VSM NW 25	S	PN 400	30	M 42 x 2	28,5	50	25,0 x 2,5
VSM NW 32	S	PN 315	38	M 52 x 2	32,5	60	33,0 x 2,5

PN = nominalni pritisak PB = maks. radni pritisak - Serija: LL = veoma lako L = lako S = teško - Ø = spoljni prečnik cevi

Varijante proizvoda

VLM VA / VSM VA Navrtka za zatvaranje, plemeniti čelik