

# W VA W90

## Navojni spoj, ugao 90°

### Osobine

Priključak 1 + 2	metrički spoljni cilindrični navoj
Oblik zaptivke 1 + 2	24° unutrašnji konus
Konstrukcija	Navojni spoj
Konstrukcija	ugao 90°
Norma	DIN 2353 ISO 8434-1
Obim isporuke	Nastavak sa preklopnom navrtkom i reznim prstenom
Materijal	plemeniti čelik

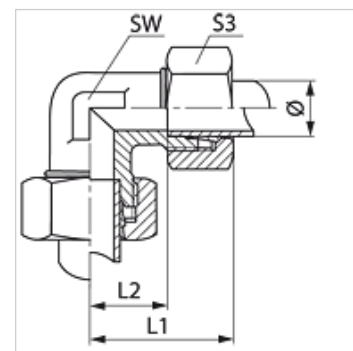

### Artikal

Naziv	Seriya	Radni pritisak bar	Cev spolja Ø (mm)	L1 (mm)	L2 (mm)	SW (mm)	S3
W 04 LL VA	LL	PN 100	4	21	11,0	7	10
W 06 LL VA	LL	PN 100	6	21	9,5	9	12
W 08 LL VA	LL	PN 100	8	23	11,5	12	14
W NW 04 HL VA	L	PN 315	6	27	12,0	12	14
W NW 06 HL VA	L	PN 315	8	29	14,0	12	17
W NW 08 HL VA	L	PN 315	10	30	15,0	14	19
W NW 10 HL VA	L	PN 315	12	32	17,0	17	22
W NW 13 HL VA	L	PN 315	15	36	21,0	19	27
W NW 16 HL VA	L	PN 315	18	40	23,5	24	32
W NW 20 HL VA	L	PN 160	22	44	27,5	27	36
W NW 25 HL VA	L	PN 160	28	47	30,5	36	41
W NW 32 HL VA	L	PN 160	35	56	34,5	41	50
W NW 40 HL VA	L	PN 160	42	63	40,0	50	60
W NW 03 HS VA	S	PN 630	6	31	16,0	12	17
W NW 04 HS VA	S	PN 630	8	32	17,0	14	19
W NW 06 HS VA	S	PN 630	10	34	17,5	17	22
W NW 08 HS VA	S	PN 630	12	38	21,5	17	24
W NW 10 HS VA	S	PN 630	14	40	22,0	19	27
W NW 13 HS VA	S	PN 400	16	43	24,5	24	30
W NW 16 HS VA	S	PN 400	20	48	26,5	27	36
W NW 20 HS VA	S	PN 400	25	54	30,0	36	46
W NW 25 HS VA	S	PN 400	30	62	35,5	41	50
W NW 32 HS VA	S	PN 315	38	72	41,0	50	60

Seriya: LL = veoma lako L = lako S = teško - PN = nominalni pritisak PB = maks. radni pritisak - Ø = spoljni prečnik cevi

### Varijante proizvoda

W	Navojni spoj, ugao 90°, čelik
W MG	Navojni spoj, ugao 90°, Mesing
XW VA	Navojni spoj, ugao 90°, plemeniti čelik