

Osobine

| | |
|---------------------------|---|
| Verzija | Uranjajući cilindar without mounting elements |
| Radni pritisak | maks. 200 bara (prema DIN EN 982) |
| Kontrolni pritisak | maks. 240 bara (prema DIN EN 982) |
| Temperaturni opseg | Standardni model -15 °C do +80 °C |
| Mediji | HLP-fluidi |
| Materijal | Klipnjača: Čelik 20MnV6, hrom 25 mikron +/- 5 Klipnjača : 120 sati postojanosti u NSS testu prema ISO 3768 Vođica klipnjače: Čelik 9SMn28 Cevni nastavak za ulje: Čelik 9SMn28 Polirana cilindrična cev: ST 52.3 DIN 2393-ISO H9 Dno cilindra: FE 510-A105 Navrtka: Čelik 8UNI EN20898/2 Zaptivka TPM: NBR Klip: Čelik 9SMn28 Zaptivka OR: NBR Fluorosil Viton Zaptivka TSE-TTS-TTI/L: NBR + pletivo / poliuretan Zaptivka GHM-GHK: NBR / poliuretan |

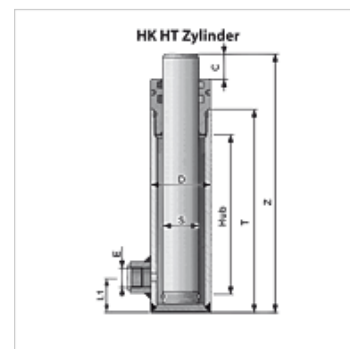

Napomena

Brzina klipa se odnosi na standardne zaptivke: maks. 25m/min - 0,42m/sek.

Brzina klipa u graničnim položajima: maks. 6m/min - 0,10m/sek.

For these standard cylinders, it is recommended not to weld any fastenings to the cylinder liner (e.g. cardan mountings) as this could distort it.

Opis

Our hydraulic cylinders and their components are designed for standard applications in industry and agriculture. They can be used only in some circumstances for applications in construction machinery. If this is your intention, please contact our technical personnel. The cylinders conform to the technical specifications in the catalogue or are designed to customers' specifications (approval drawing).

Prilikom izbora, obrade i upotrebe cilindra uzmite u obzir standard EN ISO 4413 -Zahtevi za bezbednost sistema prenosa snage i njihovi delovi- kao i utvrđivanje i zahtevi za bezbednost na osnoviu zakonskih propisa.

Artikal

| Naziv | Ø D (mm) | Ø S (mm) | Hod (mm) | Z (mm) | C (mm) | T (mm) | E | L1 (mm) | Težina (kg) |
|------------------|----------|----------|----------|--------|--------|--------|--------|---------|-------------|
| HK HT 02 30 0200 | 50 | 30 | 200 | 326 | 40,0 | 256,0 | G 3/8" | 23 | 3,64 |
| HK HT 02 30 0250 | 50 | 30 | 250 | 376 | 40,0 | 303,0 | G 3/8" | 23 | 4,19 |
| HK HT 02 30 0300 | 50 | 30 | 300 | 426 | 40,0 | 353,0 | G 3/8" | 23 | 4,75 |
| HK HT 02 30 0350 | 50 | 30 | 350 | 476 | 40,0 | 403,0 | G 3/8" | 23 | 5,31 |
| HK HT 02 30 0400 | 50 | 30 | 400 | 526 | 40,0 | 453,0 | G 3/8" | 23 | 5,86 |
| HK HT 02 30 0500 | 50 | 30 | 500 | 626 | 40,0 | 553,0 | G 3/8" | 23 | 6,96 |
| HK HT 03 40 0200 | 60 | 40 | 200 | 338 | 45,0 | 258,0 | G 3/8" | 26 | 5,64 |
| HK HT 03 40 0300 | 60 | 40 | 300 | 438 | 45,0 | 358,0 | G 3/8" | 26 | 7,29 |
| HK HT 03 40 0400 | 60 | 40 | 400 | 538 | 45,0 | 458,0 | G 3/8" | 26 | 8,98 |
| HK HT 03 40 0500 | 60 | 40 | 500 | 638 | 45,0 | 558,0 | G 3/8" | 26 | 13,00 |
| HK HT 03 40 0600 | 60 | 40 | 600 | 738 | 45,0 | 658,0 | G 3/8" | 26 | 12,28 |
| HK HT 04 50 0300 | 70 | 50 | 300 | 450 | 50,0 | 365,0 | G 3/8" | 30 | 10,47 |
| HK HT 04 50 0400 | 70 | 50 | 400 | 550 | 50,0 | 465,0 | G 3/8" | 30 | 12,86 |
| HK HT 04 50 0500 | 70 | 50 | 500 | 650 | 50,0 | 565,0 | G 3/8" | 30 | 15,14 |
| HK HT 04 50 0600 | 70 | 50 | 600 | 750 | 50,0 | 665,0 | G 3/8" | 30 | 17,50 |

Ø S = prečnik klipnjače