

## Osobine

|                         |  |
|-------------------------|--|
| <b>Konstrukcija</b>     | Komplet klip   |
| <b>Radni pritisak</b>   | maks. do 40 bara   |
| <b>Brzina max.</b>      | 0,5 m/s  |
| <b>Temperatura min.</b> | -30 °C   |
| <b>Temperatura max.</b> | 110 °C   |
| <b>Mediji</b>           | Mineralna ulja<br>Voda vazduh  |
| <b>Montaža</b>          | gumenu stranu prevući preko rukavca klipnjače i pričvrstiti pomoću podloške i navrtke. |
| <b>Materijal</b>        | 85° Shore A NBR, sa čeličnim jezgrom   |
| <b>Primena</b>          | Hidraulika   |

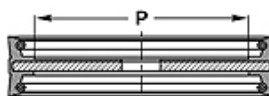

| Toleranz / Tolerance |    |        |
|----------------------|----|--------|
| D                    | d  | E      |
| H11                  | f8 | ± 0,50 |

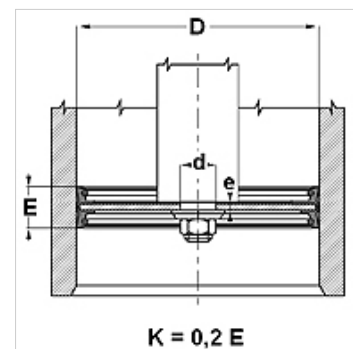

## Opis

Komplet klip.

## Napomene u vezi porudžbine

Molimo kontaktirajte nas ukoliko imate pitanja u vezi posebnih uslova rada (tečnosti, temperatura, pritisak ...).

Moguć drugi materijal: FPM.

## Artikal

| Naziv   | D<br>(mm) | d<br>(mm) | P<br>(mm) | E<br>(mm) | e<br>(mm) |
|---------|-----------|-----------|-----------|-----------|-----------|
| TDO 26  | 26        | 8,2       | 15,0      | 22        | 3,0       |
| TDO 30  | 30        | 8,2       | 16,0      | 22        | 3,0       |
| TDO 35  | 35        | 8,2       | 20,0      | 26        | 3,0       |
| TDO 40  | 40        | 10,2      | 20,0      | 22        | 3,0       |
| TDO 45  | 45        | 10,2      | 22,0      | 25        | 4,0       |
| TDO 50  | 50        | 10,2      | 27,0      | 25        | 4,0       |
| TDO 55  | 55        | 10,2      | 32,0      | 25        | 4,0       |
| TDO 60  | 60        | 12,2      | 37,0      | 26        | 4,0       |
| TDO 63  | 63        | 12,2      | 40,0      | 25        | 4,0       |
| TDO 70  | 70        | 12,2      | 44,0      | 30        | 5,0       |
| TDO 80  | 80        | 12,2      | 54,0      | 30        | 5,0       |
| TDO 100 | 100       | 12,2      | 72,0      | 35        | 6,0       |
| TDO 110 | 110       | 12,2      | 78,0      | 40        | 6,0       |
| TDO 115 | 115       | 20,2      | 83,0      | 30        | 8,0       |
| TDO 125 | 125       | 20,2      | 85,0      | 40        | 8,0       |
| TDO 140 | 140       | 20,2      | 100,0     | 40        | 10,0      |
| TDO 150 | 150       | 20,2      | 105,0     | 40        | 10,0      |
| TDO 200 | 200       | 20,2      | 146,0     | 40        | 10,0      |
| TDO 250 | 250       | 30,2      | 200,0     | 40        | 12,0      |
| TDO 300 | 300       | 35,2      | 250,0     | 40        | 12,0      |