

Özellikler

Bağlantı 1 - 3	metrik dış, silindirik
Sızdırmazlık şekli 1 - 3	24° içe havşalı
Model	Redüksiyon Bağlantı
Dizayn	T-Form
Standart	ISO 8434-1
Teslimat kapsamı	Gövde (Somun ve Yüzlüklü)
Malzeme	Paslanmaz çelik

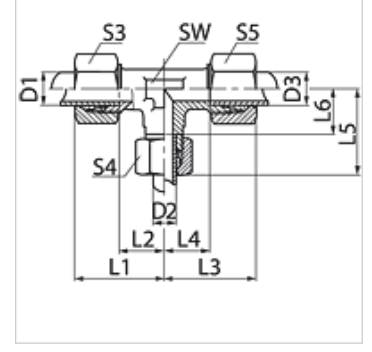

Açıklama

Montaj, Basınç Değeri ve izin verilen Çalışma Sıcaklıkları ile ilgili Bilgiler için Lütfen Boru Bağlantı Teknik Bilgilerine Bakınız.

Ürün

Tanım	Tip	Çalışma basıncı bar	D1 (mm)	D2 (mm)	D3 (mm)	L1 (mm)	L2 (mm)	L3 (mm)	L4 (mm)	L5 (mm)	L6 (mm)	SW (mm)	S3	S4	S5
RT NW 04 06 04 HL VA	L	PN 315	6	8	6	26	11,0	26	11,0	29,0	14,0	14	14	17	14
RT NW 04 08 04 HL VA	L	PN 315	6	10	6	30	15,0	30	15,0	30,0	15,0	17	14	19	14
RT NW 06 04 06 HL VA	L	PN 315	8	6	8	29	14,0	29	14,0	29,0	14,0	14	17	14	17
RT NW 06 08 06 HL VA	L	PN 315	8	10	8	30	15,0	30	15,0	30,0	15,0	17	17	19	17
RT NW 06 10 06 HL VA	L	PN 315	8	12	8	32	17,0	32	17,0	32,0	17,0	19	17	22	17
RT NW 08 04 08 HL VA	L	PN 315	10	6	10	30	15,0	30	15,0	30,0	15,0	17	19	14	19
RT NW 08 06 08 HL VA	L	PN 315	10	8	10	30	15,0	30	15,0	30,0	15,0	17	19	17	19
RT NW 08 08 04 HL VA	L	PN 315	10	10	6	30	15,0	30	15,0	30,0	15,0	17	19	19	14
RT NW 08 10 08 HL VA	L	PN 315	10	12	10	32	19,0	32	19,0	32,0	15,0	17	19	22	19
RT NW 08 13 08 HL VA	L	PN 315	10	15	10	36	21,0	36	21,0	36,0	21,0	19	19	27	19
RT NW 10 04 10 HL VA	L	PN 315	12	6	12	32	17,0	32	17,0	32,0	17,0	19	22	14	22
RT NW 10 06 06 HL VA	L	PN 315	12	8	8	32	17,0	32	17,0	32,0	17,0	19	22	17	17
RT NW 10 06 10 HL VA	L	PN 315	12	8	12	32	17,0	32	17,0	32,0	17,0	19	22	17	22
RT NW 10 08 08 HL VA	L	PN 315	12	10	10	32	17,0	32	17,0	32,0	17,0	19	22	19	19
RT NW 10 08 10 HL VA	L	PN 315	12	10	12	32	17,0	32	17,0	32,0	17,0	19	22	19	22
RT NW 10 10 08 HL VA	L	PN 315	12	12	10	32	17,0	32	17,0	32,0	17,0	19	22	22	19
RT NW 10 13 10 HL VA	L	PN 315	12	15	12	36	21,0	36	21,0	36,0	21,0	19	22	27	22
RT NW 10 16 10 HL VA	L	PN 315	12	18	12	39	24,0	39	24,0	40,0	23,5	24	22	32	22
RT NW 13 04 13 HL VA	L	PN 315	15	6	15	36	21,0	36	21,0	36,0	21,0	19	27	14	27
RT NW 13 06 13 HL VA	L	PN 315	15	8	15	36	21,0	36	21,0	36,0	21,0	19	27	17	27
RT NW 13 08 13 HL VA	L	PN 315	15	10	15	36	21,0	36	21,0	36,0	21,0	19	27	19	27
RT NW 13 10 10 HL VA	L	PN 315	15	12	12	36	21,0	36	21,0	36,0	21,0	19	27	22	22
RT NW 13 10 13 HL VA	L	PN 315	15	12	15	36	21,0	36	21,0	36,0	21,0	19	27	22	27
RT NW 13 13 10 HL VA	L	PN 315	15	15	12	36	21,0	36	21,0	36,0	21,0	19	27	27	22
RT NW 16 06 16 HL VA	L	PN 315	18	8	18	40	23,5	40	23,5	39,0	24,0	24	32	17	32
RT NW 16 08 08 HL VA	L	PN 315	18	10	10	39	23,5	39	24,0	39,0	24,0	24	32	19	19
RT NW 16 08 16 HL VA	L	PN 315	18	10	18	40	23,5	40	23,5	39,0	24,0	24	32	19	32
RT NW 16 10 16 HL VA	L	PN 315	18	12	18	40	23,5	40	23,5	39,0	24,0	24	32	22	32
RT NW 16 13 16 HL VA	L	PN 315	18	15	18	40	23,5	40	23,5	39,0	24,0	24	32	27	32
RT NW 16 16 08 HL VA	L	PN 315	18	18	10	39	23,5	39	24,0	40,0	23,5	24	32	32	19
RT NW 20 08 20 HL VA	L	PN 160	22	10	22	44	27,5	44	27,5	43,0	28,0	27	36	19	36
RT NW 20 10 20 HL VA	L	PN 160	22	12	22	44	27,5	44	27,5	43,0	28,0	27	36	22	36
RT NW 20 13 13 HL VA	L	PN 160	22	15	15	43	27,5	43	28,0	43,0	28,0	27	36	27	27
RT NW 20 13 20 HL VA	L	PN 160	22	15	22	44	27,5	44	27,5	43,0	28,0	27	36	27	36
RT NW 20 16 16 HL VA	L	PN 160	22	18	18	44	27,5	44	27,5	44,0	27,5	27	36	32	32
RT NW 20 16 20 HL VA	L	PN 160	22	18	22	44	27,5	44	27,5	44,0	27,5	27	36	32	36
RT NW 20 20 16 HL VA	L	PN 160	22	22	18	44	27,5	44	27,5	44,0	27,5	27	36	36	32
RT NW 25 08 25 HL VA	L	PN 160	28	10	28	47	30,5	47	30,5	46,0	31,0	36	41	19	41
RT NW 25 10 25 HL VA	L	PN 160	28	12	28	47	30,5	47	30,5	46,0	31,0	36	41	22	41
RT NW 25 13 25 HL VA	L	PN 160	28	15	28	47	30,5	47	30,5	46,0	31,0	36	41	27	41
RT NW 25 16 25 HL VA	L	PN 160	28	18	28	47	30,5	47	30,5	47,0	30,5	36	41	32	41
RT NW 25 20 20 HL VA	L	PN 160	28	22	22	47	30,5	47	30,5	47,0	30,5	36	41	36	36
RT NW 25 20 25 HL VA	L	PN 160	28	22	28	47	30,5	47	30,5	47,0	30,5	36	41	36	41
RT NW 25 32 25 HL VA	L	PN 160	28	35	28	45	30,5	45	30,5	53,0	34,5	41	41	50	41
RT NW 32 10 32 HL VA	L	PN 160	35	10	35	53	34,5	53	34,5	26,0	15,0	41	50	19	50
RT NW 32 13 32 HL VA	L	PN 160	35	15	35	52	34,5	52	34,5	33,0	21,0	41	50	27	50



Ürün

Tanım	Tip	Çalışma basıncı bar	D1 (mm)	D2 (mm)	D3 (mm)	L1 (mm)	L2 (mm)	L3 (mm)	L4 (mm)	L5 (mm)	L6 (mm)	SW (mm)	S3	S4	S5
RT NW 32 16 32 HL VA	L	PN 160	35	18	35	52	34,5	52	34,5	23,5	39,5	41	50	32	50
RT NW 32 20 32 HL VA	L	PN 160	35	22	35	56	34,5	56	34,5	54,0	37,5	41	50	36	50
RT NW 32 25 32 HL VA	L	PN 160	35	28	35	56	34,5	56	34,5	54,0	37,5	41	50	41	50
RT NW 32 40 32 HL VA	L	PN 160	35	42	35	52	34,5	52	34,5	56,0	40,0	50	50	60	50
RT NW 40 13 40 HL VA	L	PN 160	42	15	42	56	40,0	56	40,0	32,5	21,0	50	60	27	60
RT NW 40 16 40 HL VA	L	PN 160	42	18	42	56	40,0	56	40,0	36,0	23,5	50	60	32	60
RT NW 40 20 40 HL VA	L	PN 160	42	22	42	56	40,0	56	40,0	40,0	23,5	50	60	36	60
RT NW 40 25 40 HL VA	L	PN 160	42	28	42	56	40,0	56	40,0	43,0	30,5	50	60	50	60
RT NW 40 32 40 HL VA	L	PN 160	42	35	42	56	40,0	56	40,0	52,0	34,5	50	60	50	60
RT NW 06 03 06 HS VA	S	PN 630	10	6	10	34	17,5	34	17,5	33,0	18,0	19	22	17	22
RT NW 06 04 06 HS VA	S	PN 630	10	8	10	26	15,0	26	15,0	25,0	14,0	17	22	17	22
RT NW 08 03 08 HS VA	S	PN 630	12	6	12	38	21,5	38	21,5	37,0	22,0	22	24	17	24
RT NW 08 04 04 HS VA	S	PN 630	12	8	8	37	21,5	37	22,0	37,0	22,0	22	24	19	19
RT NW 08 04 08 HS VA	S	PN 630	12	8	12	38	21,5	38	21,5	37,0	22,0	22	24	19	24
RT NW 08 06 08 HS VA	S	PN 630	12	10	12	38	21,5	38	21,5	38,0	21,5	22	24	22	24
RT NW 08 13 08 HS VA	S	PN 400	12	16	12	42	25,5	42	25,5	43,0	24,5	24	24	30	24
RT NW 10 04 10 HS VA	S	PN 630	14	8	14	40	22,0	40	22,0	37,0	22,0	19	27	19	27
RT NW 10 06 10 HS VA	S	PN 630	14	10	14	40	22,0	40	22,0	39,0	22,5	19	27	22	27
RT NW 13 03 13 HS VA	S	PN 400	16	6	16	43	24,5	43	24,5	41,0	26,0	24	30	17	30
RT NW 13 04 13 HS VA	S	PN 400	16	8	16	43	24,5	43	24,5	41,0	26,0	24	30	19	30
RT NW 13 06 13 HS VA	S	PN 400	16	10	16	43	24,5	43	24,5	42,0	25,5	24	30	22	30
RT NW 13 08 13 HS VA	S	PN 400	16	12	16	43	24,5	43	24,5	42,0	25,5	24	30	24	30
RT NW 13 10 13 HS VA	S	PN 400	16	14	16	48	26,5	48	26,5	46,0	26,5	24	30	27	30
RT NW 13 16 13 HS VA	S	PN 400	16	20	16	48	28,5	48	28,5	48,0	26,5	27	30	36	30
RT NW 16 04 16 HS VA	S	PN 400	20	8	20	48	26,5	48	26,5	41,0	26,0	27	36	19	36
RT NW 16 06 16 HS VA	S	PN 400	20	10	20	48	26,5	48	26,5	46,0	29,5	27	36	22	36
RT NW 16 08 16 HS VA	S	PN 400	20	12	20	48	26,5	48	26,5	46,0	29,5	27	36	24	36
RT NW 16 10 16 HS VA	S	PN 400	20	14	20	48	26,5	48	26,5	46,0	29,5	27	36	30	36
RT NW 16 13 16 HS VA	S	PN 400	20	16	20	48	26,5	48	26,5	47,0	28,5	27	36	30	36
RT NW 16 20 16 HS VA	S	PN 400	20	25	20	53	31,5	53	31,5	54,0	30,0	36	36	46	36
RT NW 20 06 20 HS VA	S	PN 400	25	10	25	54	30,0	54	30,0	46,0	29,5	36	46	22	46
RT NW 20 08 20 HS VA	S	PN 400	25	12	25	54	30,0	54	30,0	46,0	26,5	36	46	24	46
RT NW 20 10 20 HS VA	S	PN 400	25	14	25	54	30,0	54	30,0	46,0	29,5	36	46	27	46
RT NW 20 13 20 HS VA	S	PN 400	25	16	25	54	30,0	54	30,0	52,0	33,5	36	46	30	46
RT NW 20 16 20 HS VA	S	PN 400	25	20	25	54	31,0	54	30,0	53,0	31,5	36	46	36	46
RT NW 20 25 20 HS VA	S	PN 400	25	30	25	61	37,0	61	37,0	62,0	35,5	41	46	50	46
RT NW 25 08 25 HS VA	S	PN 400	30	12	30	62	35,5	62	35,5	46,0	29,5	41	50	24	50
RT NW 25 13 25 HS VA	S	PN 400	30	16	30	62	35,5	62	35,5	59,0	40,5	41	46	30	50
RT NW 25 16 25 HS VA	S	PN 400	30	20	30	62	35,5	62	35,5	60,0	38,5	41	50	36	50
RT NW 25 20 25 HS VA	S	PN 400	30	25	30	62	35,5	62	35,5	61,0	37,0	41	50	46	50
RT NW 25 32 25 HS VA	S	PN 400	30	38	30	62	35,5	62	35,5	67,0	41,0	50	50	60	50
RT NW 32 13 32 HS VA	S	PN 315	38	16	38	67	41,0	67	41,0	49,0	24,5	50	60	30	60
RT NW 32 16 32 HS VA	S	PN 315	38	20	38	67	41,0	67	41,0	54,0	26,5	50	60	36	60
RT NW 32 20 32 HS VA	S	PN 315	38	25	38	67	41,0	67	41,0	50,0	30,0	50	60	46	60
RT NW 32 25 32 HS VA	S	PN 315	38	30	38	67	41,0	67	41,0	58,0	35,5	50	60	50	60

Model: LL = Çok hafif L = Hafif S = Ağır - PN=Çalışma Basıncı PB=Patlama Basıncı - D1, D2, D3 = boru dış çapı

Ürün türleri

RT	Redüksiyon Bağlantı, T-Form, Çelik
XRT VA	Redüksiyon Bağlantı, T-Form, Paslanmaz çelik