

# GFS N M (3000 / 6000 PSI)

SAE Blok Karşı Flanşı, NPT

**HANSA FLEX**

## Özellikler

Standart	SAE J 518 C ISO 6162
Dizayn	düz
Model	SAE blok Karşı flanşı
Sabitleme	İç diş, metr. Vidalar
Teslimat kapsamı	sadece flanş
Malzeme	S355J2G3 (ST52.3)
Yüzey koruması	siyah yağlı

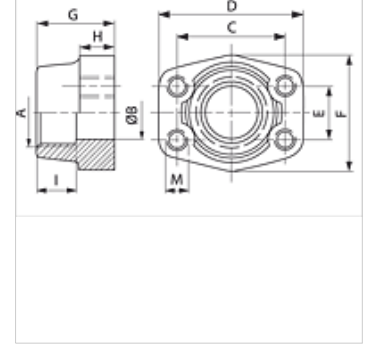
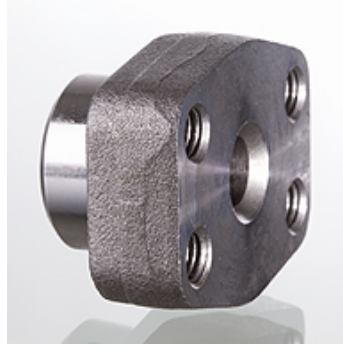

## Açıklama

Verilen Maksimum Çalışma Basıncı, Flanşla İlgilidir! Gerçek Çalışma Basıncı, Boru (Et Kalınlığı) ve Borunun Kalitesi ile Belirlenir!

## Ürün

Tanım	Basınç serisi	PB 10.9 (bar)	Model ebadı	A	Ø B (mm)	C (mm)	TR (mm)	E (mm)	F (mm)	G (mm)	H (mm)	I (mm)	M metr.
GFS 80 N	3000 PSI	350	1/2"	NPT 1/2" -14	13	38,1	54	17,5	46	36	16	19	M 8
GFS 80 N 3/8	3000 PSI	350	1/2"	NPT 3/8" -18	13	38,1	54	17,5	46	36	16	19	M 8
GFS 100 N	3000 PSI	350	3/4"	NPT 3/4" -14	19	47,6	65	22,2	50	36	18	19	M 10
GFS 100 N 1/2	3000 PSI	350	3/4"	NPT 1/2" -14	13	47,6	65	22,2	50	36	18	19	M 10
GFS 102 N	3000 PSI	315	1"	NPT 1" -11,5	25	52,4	70	26,2	55	38	18	22	M 10
GFS 102 N 3/4	3000 PSI	315	1"	NPT 3/4" -14	19	52,4	70	26,2	55	35	21	19	M 10
GFS 104 N	3000 PSI	250	1.1/4"	NPT 1.1/4" -11,5	32	58,7	79	30,2	68	41	21	22	M 10
GFS 104 N 1	3000 PSI	250	1.1/4"	NPT 1" -11,5	25	58,7	81	30,2	65	42	25	22	M 10
GFS 106 N	3000 PSI	200	1.1/2"	NPT 1.1/2"	38	69,9	93	35,7	78	45	25	24	M 12
GFS 106 N 1 1/4	3000 PSI	200	1.1/2"	NPT 1.1/4" -11,5	32	69,9	95	35,7	78	45	27	24	M 12
GFS 108 N	3000 PSI	200	2"	NPT 2" -11,5	51	77,8	102	42,9	90	45	25	30	M 12
GFS 108 N 1 1/2	3000 PSI	200	2"	NPT 1.1/2"	38	77,8	102	42,9	90	45	25	26	M 12
GFS 110 N	3000 PSI	160	2.1/2"	NPT 2.1/2" -11,5	63	88,9	114	50,8	105	50	25	30	M 12
GFS 112 N	3000 PSI	138	3"	NPT 3" -11,5	73	106,4	134	61,9	124	50	27	34	M 16
GFS 114 N	3000 PSI	35	3.1/2"	NPT 3.1/2" -11,5	89	120,7	152	69,9	136	48	27	34	M 16
GFS 116 N	3000 PSI	35	4"	NPT 4" -11,5	99	130,2	162	77,8	146	48	27	34	M 16
GFS 401 N	6000 PSI	400	1/2"	NPT 1/2" -14	13	40,5	54	18,2	46	36	16	19	M 8
GFS 401 N 3/8	6000 PSI	400	1/2"	NPT 3/8" -18	13	40,5	54	18,2	46	36	16	19	M 8
GFS 402 N	6000 PSI	400	3/4"	NPT 3/4" -14	19	50,8	71	23,8	55	35	21	22	M 10
GFS 402 N 1/2	6000 PSI	400	3/4"	NPT 1/2" -14	13	50,8	71	23,8	55	35	21	22	M 10
GFS 403 N	6000 PSI	400	1"	NPT 1" -11,5	25	57,2	81	27,8	65	42	25	24	M 12
GFS 403 N 3/4	6000 PSI	400	1"	NPT 3/4" -14	19	57,2	81	27,8	65	42	25	24	M 12
GFS 404 N	6000 PSI	400	1.1/4"	NPT 1.1/4" -11,5	32	66,7	95	31,8	78	45	27	25	M 14
GFS 404 N 1	6000 PSI	400	1.1/4"	NPT 1" -11,5	25	66,7	95	31,8	78	45	27	25	M 14
GFS 405 N	6000 PSI	400	1.1/2"	NPT 1.1/2"	38	79,4	112	36,5	94	50	30	28	M 16
GFS 405 N 1 1/4	6000 PSI	400	1.1/2"	NPT 1.1/4" -11,5	32	79,4	112	36,5	94	50	30	28	M 16
GFS 406 N	6000 PSI	400	2"	NPT 2" -11,5	51	96,8	134	44,5	114	65	37	30	M 20
GFS 406 N 1 1/2	6000 PSI	400	2"	NPT 1.1/2"	38	96,8	134	44,5	114	65	37	30	M 20

PN=Çalışma Basıncı PB=Patlama Basıncı

## Ürün türleri

GFS N U (3000 / 6000 PSI) SAE Blok Karşı Flanşı, NPT, sadece flanş