

SFS U (3000 PSI)

SAE Kaynak Ucu

HANSA FLEX

Özellikler

Basınç serisi	3000 psi
Standart	SAE J 518 C ISO 6162
Dizayn	düz
Model	SAE Kaynak Ucu
Teslimat kapsamı	ile 2 flanş yarısı, vida seti ve conta halkası
Malzeme	S355J2G3 (ST52.3)

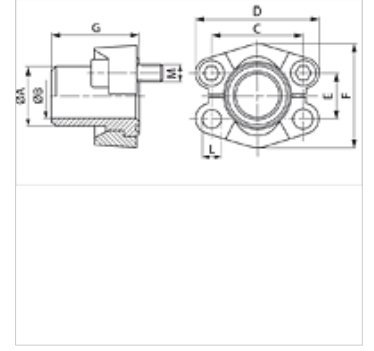
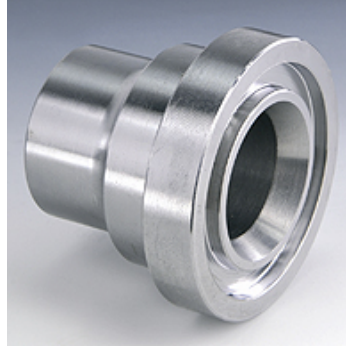

Açıklama

Verilen Maksimum Çalışma Basıncı, Flanşla İlgilidir! Gerçek Çalışma Basıncı, Boru (Et Kalınlığı) ve Borunun Kalitesi ile Belirlenir!

Ürün

Tanım	PB 10.9 (bar)	Model ebadı	Boru	A (mm)	Ø B (mm)	C (mm)	TR (mm)	E (mm)	F (mm)	G (mm)	L (mm)	M metr.	M unc
SFS 3001-S 16 U	350	1/2"	16 x 2	16,0	12,0	38,1	54	17,5	45,6	41	8,5	M 8 x 25	5/16" x 1.1/4"
SFS 3001-21.3 U	350	1/2"	21,3 x 2,9	22,0	15,5	38,1	54	17,5	45,6	41	8,5	M 8 x 30	5/16" x 1.1/4"
SFS 3002-25 U	350	3/4"	25 x 3	27,0	18,9	47,6	65	22,2	51,8	50	10,5	M 10 x 30	3/8" x 1.1/4"
SFS 3002-26.9 U	350	3/4"	26,9 x 3,9	27,0	18,9	47,6	65	22,2	51,8	50	10,5	M 10 x 30	3/8" x 1.1/4"
SFS 3003-28 U	315	1"	28 x 3	28,0	22,0	52,4	70	26,2	58,4	50	10,5	M 10 x 35	3/8" x 1.1/4"
SFS 3003-30 U	315	1"	30 x 4	30,0	22,0	52,4	70	26,2	58,4	50	10,5	M 10 x 35	3/8" x 1.1/4"
SFS 3003-33.7 U	315	1"	33,7 x 4,5	35,0	24,7	52,4	70	26,2	58,4	50	10,5	M 10 x 35	3/8" x 1.1/4"
SFS 3003-38 U	315	1"	38 x 5	38,0	28,0	52,4	70	26,2	58,4	50	10,5	M 10 x 35	3/8" x 1.1/4"
SFS 3004-38 U	250	1.1/4"	38 x 5	38,0	28,0	58,7	79	30,2	72,6	55	*1	*2	7/16" x 1.1/2"
SFS 3004-42.4 U	250	1.1/4"	42,4 x 6,3	43,0	29,7	58,7	79	30,2	72,6	55	*1	*2	7/16" x 1.1/2"
SFS 3005-38 U	200	1.1/2"	38 x 4	38,0	30,0	69,9	94	35,7	82,2	57	13,5	M 12 x 35	1/2" x 1.1/2"
SFS 3005-42 U	200	1.1/2"	42 x 5	42,0	32,0	69,9	94	35,7	82,2	57	13,5	M 12 x 35	1/2" x 1.1/2"
SFS 3005-45 U	200	1.1/2"	45 x 5	45,0	35,0	69,9	94	35,7	82,2	57	13,5	M 12 x 35	1/2" x 1.1/2"
SFS 3005-48.3 U	200	1.1/2"	48,3 x 7,1	49,0	34,0	69,9	94	35,7	82,2	57	13,5	M 12 x 35	1/2" x 1.1/2"
SFS 3006-55 U	200	2"	55 x 5	55,0	45,0	77,8	102	42,9	96,4	57	13,5	M 12 x 35	1/2" x 1.1/2"
SFS 3006-60.3 U	200	2"	60,3 x 8	60,3	44,0	77,8	102	42,9	96,4	57	13,5	M 12 x 35	1/2" x 1.1/2"
SFS 3007-65 U	160	2.1/2"	65 x 6	65,0	53,0	88,9	114	50,8	108,2	58	13,5	M 12 x 40	1/2" x 1.3/4"
SFS 3007-70 U	160	2.1/2"	70 x 7,5	70,0	55,0	88,9	114	50,8	108,2	58	13,5	M 12 x 40	1/2" x 1.3/4"
SFS 3007-76.1 U	160	2.1/2"	76,1 x 7,1	74,0	62,0	88,9	114	50,8	108,2	58	13,5	M 12 x 40	1/2" x 1.3/4"
SFS 3008-80 U	138	3"	80 x 6	80,0	68,0	106,4	135	61,9	130,6	60	16,7	M 16 x 45	5/8" x 2"
SFS 3008-88.9 U	138	3"	88,9 x 7	90,0	73,0	106,4	135	61,9	130,6	60	16,7	M 16 x 45	5/8" x 2"
SFS 3009-100 U	35	3.1/2"	100 x 6	100,0	88,0	120,7	152	69,9	139,0	60	17,0	M 16 x 45	5/8" x 2"
SFS 3009-88.9 U	35	3.1/2"	88,9 x 8	90,0	73,0	120,7	152	69,9	139,0	60	17,0	M 16 x 45	5/8" x 2"
SFS 3010-110 U	35	4"	110 x 6	110,0	98,0	130,2	162	77,8	152,0	60	17,0	M 16 x 50	5/8" x 2"
SFS 3010-114.3 U	35	4"	114,3 x 8,8	115,0	96,7	130,2	162	77,8	152,0	60	17,0	M 16 x 50	5/8" x 2"
SFS 3011-133 U	35	5"	133 x 6,5	133,0	120,0	152,4	184	92,1	180,0	60	17,0	M 16 x 50	5/8" x 2"
SFS 3011-139.7 U	35	5"	139,7 x 10	140,0	120,0	152,4	184	92,1	180,0	60	17,0	M 16 x 50	5/8" x 2"

PN=Çalışma Basıncı PB=Patlama Basıncı - Model: LL = Çok hafif L = Hafif S = Ağır - çap = Boru dış çapı

*1) = isteğe bağlı olarak 10,5 veya 12,5 - *2) = isteğe bağlı olarak M 10 x 30 veya M 12 x 35

Ürün türleri

SFS (3000 PSI)	SAE Kaynak Ucu, sadece ön kaynak demeti
SFS M (3000 PSI)	SAE Kaynak Ucu, ile 2 flanş yarısı, vida seti ve conta halkası