

PR V2 (M)

Çelik Çekme Boru, Metrik, 1.4541

HANSA FLEX

Özellikler

Model	Çelik Çekme Boru, metrik
Malzeme	Paslanmaz çelik 1.4541
Boru uzunluğu	6 metre

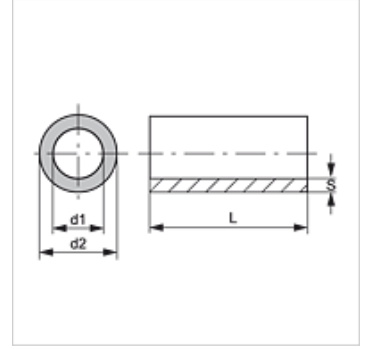
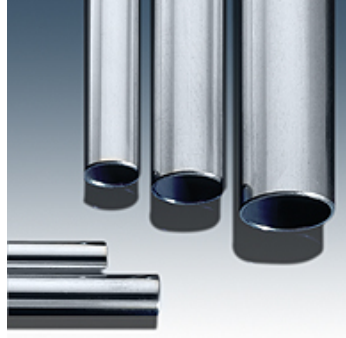

Ürün

Tanım	Ø d2 (mm)	AD toleransı +/- (mm)	Ø d1 (mm)	S (mm)	ID toleransı +/- (mm)	Yüklenme durumu I (bar)	Yüklenme durumu III (bar)
PR 22-3 V2	22,0	-	16,0	3,00	-	-	-
PR 38-4 V2	38,0	-	30,0	4,00	-	-	-
PR 04-1 V2	4,0	0,08	2,0	1,00	0,15	567	387
PR 06-1 V2	6,0	0,08	4,0	1,00	0,15	379	272
PR 06-1.5 V2	6,0	-	3,0	1,50	-	-	-
PR 08-1 V2	8,0	0,08	6,0	1,00	0,15	284	210
PR 08-1.5 V2	8,0	0,08	5,0	1,50	0,15	469	328
PR 10-1 V2	10,0	0,08	8,0	1,00	0,15	227	171
PR 10-1.5 V2	10,0	0,08	7,0	1,50	0,15	375	270
PR 10-2 V2	10,0	0,08	6,0	2,00	0,15	523	360
PR 12-1 V2	12,0	0,08	10,0	1,00	0,15	189	144
PR 12-1.5 V2	12,0	0,08	9,0	1,50	0,15	313	229
PR 12-2 V2	12,0	0,08	8,0	2,00	0,15	436	308
PR 14-1 V2	14,0	0,08	12,0	1,00	0,15	162	125
PR 14-2 V2	14,0	0,08	10,0	2,00	0,15	374	269
PR 14-2.5 V2	14,0	0,08	9,0	2,50	0,15	478	334
PR 15-1 V2	15,0	0,08	13,0	1,00	0,08	165	127
PR 15-1.5 V2	15,0	0,08	12,0	1,50	0,15	250	187
PR 15-2 V2	15,0	0,08	11,0	2,00	0,15	349	253
PR 15-2.5 V2	15,0	-	10,0	2,50	-	-	-
PR 16-1 V2	16,0	0,08	14,0	1,00	0,15	155	119
PR 16-1.5 V2	16,0	0,08	13,0	1,50	0,15	234	176
PR 16-2 V2	16,0	0,08	12,0	2,00	0,15	327	239
PR 18-1 V2	18,0	0,08	16,0	1,00	0,08	138	107
PR 18-1.5 V2	18,0	0,08	15,0	1,50	0,08	220	166
PR 18-2 V2	18,0	0,08	14,0	2,00	0,08	302	222
PR 18-2.5 V2	18,0	0,08	13,0	2,50	0,15	373	268
PR 18-3 V2	18,0	-	12,0	3,00	-	-	-
PR 20-1 V2	20,0	0,08	18,0	1,00	0,08	124	96
PR 20-1.5 V2	20,0	0,08	17,0	1,50	0,15	187	143
PR 20-2 V2	20,0	0,08	16,0	2,00	0,15	261	195
PR 20-2.5 V2	20,0	0,08	15,0	2,50	0,15	335	244
PR 20-3 V2	20,0	0,08	14,0	3,00	0,08	420	298
PR 22-1 V2	22,0	0,08	20,0	1,00	0,08	113	88
PR 22-1.5 V2	22,0	0,08	19,0	1,50	0,08	180	137
PR 22-2 V2	22,0	0,08	18,0	2,00	0,15	238	178
PR 22-2.5 V2	22,0	0,08	17,0	2,50	0,15	305	224
PR 23-1.5 V2	23,0	0,08	20,0	1,50	0,15	163	125
PR 25-2 V2	25,0	0,08	21,0	2,00	0,08	217	164
PR 25-2.5 V2	25,0	0,08	20,0	2,50	0,08	277	205
PR 25-3 V2	25,0	0,08	19,0	3,00	0,08	336	244
PR 25-4 V2	25,0	-	17,0	4,00	-	-	-
PR 26-3 V2	26,0	0,08	20,0	3,00	0,15	273	202
PR 28-1 V2	28,0	0,08	26,0	1,00	0,08	88	69
PR 28-2 V2	28,0	0,08	24,0	2,00	0,08	194	147
PR 28-2.5 V2	28,0	0,08	23,0	2,50	0,08	247	185
PR 28-3 V2	28,0	0,08	22,0	3,00	0,15	292	216
PR 28-4 V2	28,0	0,08	20,0	4,00	0,15	398	284
PR 30-1.5 V2	30,0	0,08	27,0	1,50	0,08	132	102
PR 30-2 V2	30,0	0,08	26,0	2,00	0,08	181	138



PR V2 (M)

Çelik Çekme Boru, Metrik, 1.4541

HANSA FLEX

Ürün

Tanım	Ø d2 (mm)	AD toleransı +/- (mm)	Ø d1 (mm)	S (mm)	ID toleransı +/- (mm)	Yüklenme durumu I (bar)	Yüklenme durumu III (bar)
PR 30-2.5 V2	30,0	0,15	25,0	2,50	0,15	216	154
PR 30-3 V2	30,0	0,08	24,0	3,00	0,15	273	202
PR 30-4 V2	30,0	0,08	22,0	4,00	0,15	371	267
PR 30-5 V2	30,0	0,08	20,0	5,00	0,15	496	347
PR 32-1.5 V2	32,0	0,15	29,0	1,50	0,15	110	86
PR 32-2 V2	32,0	0,15	28,0	2,00	0,15	157	121
PR 32-2.5 V2	32,0	0,15	27,0	2,50	0,15	203	154
PR 32-4 V2	32,0	0,08	24,0	4,00	0,08	181	138
PR 34-2 V2	34,0	0,15	30,0	2,00	0,15	147	114
PR 35-1.5 V2	35,0	0,15	32,0	1,50	0,15	101	79
PR 38-2 V2	38,0	0,15	34,0	2,00	0,15	132	102
PR 38-3 V2	38,0	0,15	32,0	3,00	0,15	210	159
PR 38-5 V2	38,0	-	28,0	5,00	-	-	-
PR 40-1.5 V2	40,0	0,15	37,0	1,50	0,15	87	69
PR 42-2 V2	42,0	0,20	38,0	2,00	0,20	112	88
PR 42-3 V2	42,0	-	36,0	3,00	-	-	-
PR 42-6 V2	42,0	0,25	30,0	6,00	0,25	387	277
PR 54-2 V 2	54,0	0,25	50,0	2,00	0,25	82	64