

PR V4 (M)

Çelik Çekme Boru, Metrik, 1.4571

HANSA FLEX

Özellikler

Model	Çelik Çekme Boru, metrik
Malzeme	Paslanmaz çelik 1.4571
Boru uzunluğu	6 metre

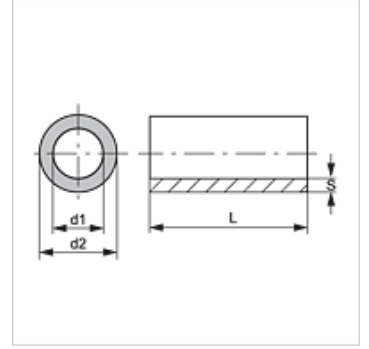
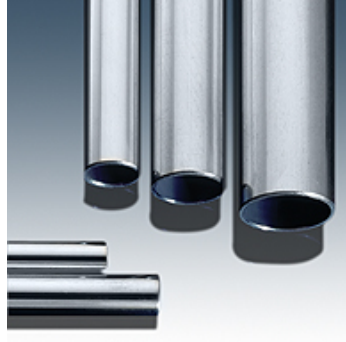

Açıklama

Verilen Basınç Değerleri, Düz Borular İçin Geçerlidir.

Boru Bükümlü Olduğunda Uygun Boru Et Kalınlıklarının, DIN EN 13480-4'e Analog bir Şekilde Hesaplanması Gerekir.

Ek bilgiler

Analog hesaplama DIN 2413 (taslak)

Yüklenme durumu I: Statik (maksimum 100 °C)

Yüklenme durumu III: Dinamik (maksimum 200 °C) salınma genişliği = P bar

Mukavemet tanım değeri: K 234 [N/mm²]

Güvenlik ek değeri: S 1,5

Sürekli kabarma sağlamlığı: $\sigma_{Sch/D}$ 190 [N/mm²]

Toleranslar: DIN 10305-4

Gerdirme sınırı, DIN 10216-5 Rp 1,0 maksimum 50°C

Ürün

Tanım	Ø d2 (mm)	AD toleransı +/- (mm)	Ø d1 (mm)	S (mm)	ID toleransı +/- (mm)	Yüklenme durumu I (bar)	Yüklenme durumu III (bar)
PR 34-2 V4	34,0	-	30,0	2,00	-	-	-
PR 14-1 V4	14,0	-	12,0	1,00	-	-	-
PR 04-0.5 V4	4,0	-	3,0	0,50	-	-	-
PR 04-1 V4	4,0	0,08	2,0	1,00	0,15	600	408
PR 05-0.5 V4	5,0	-	4,0	0,50	-	-	-
PR 05-1 V4	5,0	-	3,0	1,00	-	-	-
PR 06-0.5 V4	6,0	0,08	5,0	0,50	0,15	-	-
PR 06-1 V4	6,0	0,08	4,0	1,00	0,15	400	287
PR 06-1.5 V4	6,0	0,08	3,0	1,50	0,15	660	442
PR 06-2 V4	6,0	0,08	2,0	2,00	0,15	915	575
PR 08-1 V4	8,0	0,08	6,0	1,00	0,15	300	222
PR 08-1.5 V4	8,0	0,08	5,0	1,50	0,15	495	347
PR 08-2 V4	8,0	0,08	4,0	2,00	0,15	690	458
PR 08-2.5 V4	8,0	-	3,0	2,50	-	-	-
PR 10-0.5 V4	10,0	0,08	9,0	0,50	0,08	105	81
PR 10-1 V4	10,0	0,08	8,0	1,00	0,15	240	181
PR 10-1.2 V4	10,0	-	7,6	1,20	-	-	-
PR 10-1.5 V4	10,0	0,08	7,0	1,50	0,15	396	285
PR 10-2 V4	10,0	0,08	6,0	2,00	0,15	552	380
PR 10-2.5 V4	10,0	-	5,0	2,50	-	-	-
PR 12-1 V4	12,0	0,08	10,0	1,00	0,15	200	152
PR 12-1.5 V4	12,0	0,08	9,0	1,50	0,15	330	242
PR 12-2 V4	12,0	0,08	8,0	2,00	0,15	460	325
PR 12-3 V4	12,0	0,08	6,0	3,00	0,25	694	461
PR 13-1 V4	13,0	-	11,0	1,00	-	-	-
PR 14-1.5 V4	14,0	0,08	11,0	1,50	0,15	283	210
PR 14-2 V4	14,0	0,08	10,0	2,00	0,15	394	284
PR 14-2.5 V4	14,0	0,08	9,0	2,50	0,15	505	353
PR 14-3 V4	14,0	-	8,0	3,00	-	-	-
PR 15-1 V4	15,0	0,08	13,0	1,00	0,08	174	134
PR 15-1.5 V4	15,0	0,08	12,0	1,50	0,15	264	197
PR 15-2 V4	15,0	0,08	11,0	2,00	0,15	368	267
PR 16-1 V 4	16,0	-	14,0	1,00	-	-	-
PR 16-1.5 V4	16,0	0,08	13,0	1,50	0,08	261	195



Titiz kontrole rağmen hatalar önlenemez ve sorumluluk altında bırakmayan bilgiler hakkında hiçbir sorumluluk kabul edilmez.

25.08.2024

HANSA-FLEX AG

www.hansa-flex.com

1

PR V4 (M)

Çelik Çekme Boru, Metrik, 1.4571

HANSA FLEX

Ürün

Tanım	Ø d2 (mm)	AD toleransı +/- (mm)	Ø d1 (mm)	S (mm)	ID toleransı +/- (mm)	Yüklenme durumu I (bar)	Yüklenme durumu III (bar)
PR 16-2 V4	16,0	0,08	12,0	2,00	0,15	345	252
PR 16-2.5 V4	16,0	0,08	11,0	2,50	0,15	442	314
PR 16-3 V4	16,0	0,08	10,0	3,00	0,15	540	373
PR 16-4 V4	16,0	-	8,0	4,00	-	-	-
PR 18-1 V4	18,0	0,08	16,0	1,00	0,08	145	112
PR 18-1.5 V4	18,0	0,08	15,0	1,50	0,08	232	175
PR 18-2 V4	18,0	0,08	14,0	2,00	0,08	318	234
PR 18-2.5 V4	18,0	0,08	13,0	2,50	0,15	393	283
PR 18-3 V4	18,0	-	12,0	3,00	-	-	-
PR 18-4 V4	18,0	-	10,0	4,00	-	-	-
PR 20-1 V 4	20,0	0,08	18,0	1,00	-	-	-
PR 20-1.5 V 4	20,0	0,08	17,0	1,50	-	-	-
PR 20-2 V4	20,0	0,08	16,0	2,00	0,08	287	213
PR 20-2.5 V4	20,0	0,08	15,0	2,50	0,15	354	258
PR 20-3 V4	20,0	0,08	14,0	3,00	0,15	432	308
PR 20-3.5 V4	20,0	0,08	13,0	3,50	0,15	510	355
PR 20-4 V4	20,0	-	12,0	4,00	-	-	-
PR 22-1 V 4	22,0	0,08	20,0	1,00	-	-	-
PR 22-1.5 V4	22,0	0,08	19,0	1,50	0,08	190	145
PR 22-2 V4	22,0	0,08	18,0	2,00	0,08	260	195
PR 22-2.5 V4	22,0	0,08	17,0	2,50	0,15	321	236
PR 22-3 V4	22,0	0,08	16,0	3,00	0,15	392	283
PR 22-4 V4	22,0	-	14,0	4,00	-	-	-
PR 22-6 V4	22,0	-	10,0	6,00	-	-	-
PR 23-1.5 V4	23,0	-	20,0	1,50	-	-	-
PR 24-4 V4	24,0	-	16,0	4,00	-	-	-
PR 25-1.5 V4	25,0	0,08	22,0	1,50	0,08	167	128
PR 25-2 V4	25,0	0,08	21,0	2,00	0,08	229	173
PR 25-2.5 V4	25,0	0,08	20,0	2,50	0,08	292	216
PR 25-3 V4	25,0	0,08	19,0	3,00	0,15	345	252
PR 25-4 V4	25,0	-	17,0	4,00	-	-	-
PR 25-5 V4	25,0	-	15,0	5,00	-	-	-
PR 25-6 V4	25,0	-	13,0	6,00	-	-	-
PR 28-1 V4	28,0	-	26,0	1,00	-	-	-
PR 28-1.5 V4	28,0	0,08	25,0	1,50	0,08	149	115
PR 28-2 V4	28,0	0,08	24,0	2,00	0,08	205	156
PR 28-2.5 V4	28,0	0,08	23,0	2,50	0,08	260	195
PR 28-3 V4	28,0	-	22,0	3,00	-	-	-
PR 28-4 V4	28,0	-	20,0	4,00	-	-	-
PR 28-5 V4	28,0	-	18,0	5,00	-	-	-
PR 30-2 V4	30,0	0,08	26,0	2,00	0,08	191	146
PR 30-2.5 V4	30,0	0,08	25,0	2,50	0,08	243	183
PR 30-3 V4	30,0	0,08	24,0	3,00	0,15	288	214
PR 30-4 V4	30,0	0,08	22,0	4,00	0,15	392	282
PR 30-5 V4	30,0	0,08	20,0	5,00	0,15	496	347
PR 32-1.5 V4	32,0	-	29,0	1,50	-	-	-
PR 32-2 V4	32,0	-	28,0	2,00	-	-	-
PR 32-2.5 V4	32,0	-	27,0	2,50	-	-	-
PR 32-4 V4	32,0	-	26,0	4,00	-	-	-
PR 32-6 V4	32,0	-	20,0	6,00	-	-	-
PR 35-1.5 V 4	35,0	0,08	32,0	1,50	0,08	119	93
PR 35-2 V4	35,0	0,15	31,0	2,00	0,15	151	117
PR 35-2.5 V4	35,0	0,15	30,0	2,50	0,15	196	149
PR 35-3 V4	35,0	-	29,0	3,00	-	-	-
PR 35-4 V4	35,0	-	27,0	4,00	-	-	-
PR 35-5 V 4	35,0	0,15	25,0	5,00	0,15	418	299
PR 38-1.5 V4	38,0	-	35,0	1,50	-	-	-
PR 38-2 V4	38,0	-	34,0	2,00	-	-	-
PR 38-2.6 V4	38,0	-	32,8	2,60	-	-	-
PR 38-3 V4	38,0	-	32,0	3,00	-	-	-
PR 38-4 V4	38,0	0,15	30,0	4,00	0,15	303	224
PR 38-5 V4	38,0	0,15	28,0	5,00	0,15	385	278
PR 38-6 V4	38,0	-	26,0	6,00	-	-	-



Titiz kontrole rağmen hatalar önlenemez ve sorumluluk altında bırakmayan bilgiler hakkında hiçbir sorumluluk kabul edilmez.

25.08.2024

HANSA-FLEX AG

www.hansa-flex.com

2

PR V4 (M)

Çelik Çekme Boru, Metrik, 1.4571

HANSA FLEX

Ürün

Tanım	Ø d2 (mm)	AD toleransı +/- (mm)	Ø d1 (mm)	S (mm)	ID toleransı +/- (mm)	Yüklenme durumu I (bar)	Yüklenme durumu III (bar)
PR 40-2 V4	40,0	-	36,0	2,00	-	-	-
PR 42-2 V4	42,0	0,20	38,0	2,00	0,20	118	92
PR 42-3 V4	42,0	0,20	36,0	3,00	0,20	193	147
PR 42-6 V4	42,0	-	30,0	6,00	-	-	-
PR 43-1.5 V4	43,0	-	40,0	1,50	-	-	-
PR 50-1.5 V4	50,0	-	47,0	1,50	-	-	-
PR 50-2 V4	50,0	-	46,0	2,00	-	-	-
PR 50-4 V4	50,0	-	42,0	4,00	-	-	-
PR 50-5 V4	50,0	-	40,0	5,00	-	-	-
PR 50-6 V4	50,0	-	38,0	6,00	-	-	-
PR 54-2 V4	54,0	-	50,0	2,00	-	-	-
PR 57-2 V4	57,0	-	53,0	2,00	-	-	-
PR 63.5-1.5 V4	63,5	-	60,5	1,50	-	-	-
PR 64-2 V4	64,0	-	60,0	2,00	-	-	-
PR 70-1.5 V4	70,0	-	67,0	1,50	-	-	-
PR 70-2 V4	70,0	-	66,0	2,00	-	-	-
PR 70-5 V4	70,0	-	60,0	5,00	-	-	-
PR 101.5-2 V4	101,5	-	97,5	2,00	-	-	-
PR 108-3 V4	108,0	-	102,0	3,00	-	-	-
PR 129-2 V4	129,0	-	125,0	2,00	-	-	-
PR 133-4 V4	133,0	-	125,0	4,00	-	-	-
PR 152-2 V4	152,0	-	148,0	2,00	-	-	-
PR 159-4.5 V4	159,0	-	150,0	4,50	-	-	-