

Özellikler

Malzeme Çelik S355J0 (Fe510C)

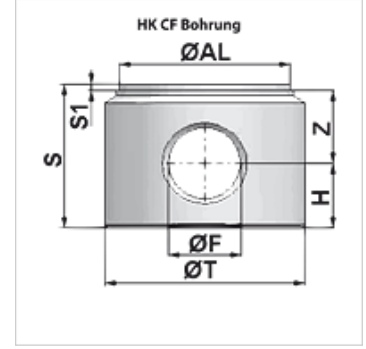

Ürün

Tanım	Ø AL (mm)	Ø F (mm)	çap T (mm)	H (mm)	S (mm)	S1 (mm)	Z (mm)	Ağırlık (kg)
HK CF 040 050 16	40	16,20	50	15,0	35	2	18,0	0,42
HK CF 050 060 20	50	20,25	60	20,0	45	2	23,0	0,80
HK CF 060 070 25	60	25,25	70	22,5	50	2	25,5	1,20
HK CF 070 080 25	70	25,25	80	22,5	50	2	25,5	1,60
HK CF 080 095 30	80	30,25	95	25,0	60	2	33,0	2,70
HK CF 100 115 35	100	35,25	115	30,0	70	2	38,0	4,70