

属性

接口 1	米制外螺纹,圆锥形
密封形式 1	螺纹密封式
接口 2	米制外螺纹,圆柱形
密封形式 2	24°内锥
结构类型	旋入式螺栓连接
结构形式	直道
标准	DIN 2353 ISO 8434-1
供货范围	带锁紧螺母和切割环的接套
原料	钢
表面保护	电镀涂层

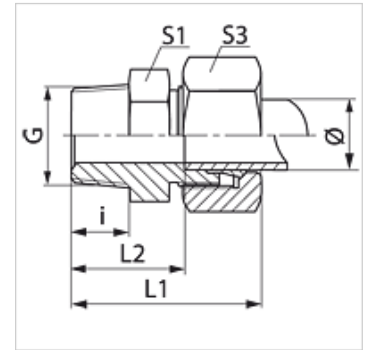

提示

有关安装、装入、压力负荷和允许的工作温度的说明请您参阅管螺栓连接的技术信息。

货品

名称	结构系列	工作压力 巴	管外径 Ø (mm)	G	i (mm)	L1 (mm)	L2 (mm)	S1	S3
VM 04 LL	LL	PN 100	4	M 8 x 1 K	8	26,0	16,0	11	10
VM 04 LL 10	LL	PN 100	4	M 10 x 1 K	8	26,0	16,0	11	10
VM 04 LL 6	LL	PN 100	4	M 6 x 1 K	8	27,0	16,0	10	10
VM 05 LL	LL	PN 100	5	M 8 x 1 K	8	26,0	14,5	11	12
VM 06 LL	LL	PN 100	6	M 10 x 1 K	8	26,0	14,5	11	12
VM 06 LL 6	LL	PN 100	6	M 6 x 1 K	8	27,5	14,5	11	12
VM 06 LL 8	LL	PN 100	6	M 8 x 1 K	8	26,0	14,5	11	12
VM 08 LL	LL	PN 100	8	M 10 x 1 K	8	28,0	16,5	12	14
VM 12 LL	LL	PN 100	12	M 16 x 1.5 K	12	32,0	20,0	17	19
VMK NW 04 HL	L	PN 315	6	M 10 x 1.5 K	10	23,0	17,0	12	14
VMK NW 06 HL	L	PN 315	8	M 12 x 1.5 K	12	25,0	20,0	17	17
VMK NW 08 HL	L	PN 315	10	M 14 x 1.5 K	12	26,0	21,0	17	19
VMK NW 10 HL	L	PN 315	12	M 16 x 1.5 K	12	27,0	22,0	19	22
VMK NW 13 HL	L	PN 315	15	M 18 x 1.5 K	12	29,0	23,0	24	27
VMK NW 16 HL	L	PN 315	18	M 22 x 1.5 K	14	31,0	25,5	27	32
VMK NW 20 HL	L	PN 160	22	M 26 x 1.5 k	18	33,0	31,5	32	36
VMK NW 25 HL	L	PN 160	28	M 33 x 2 K	20	34,0	34,5	41	41
VMK NW 32 HL	L	PN 160	35	M 42 x 2 K	21	39,0	35,5	46	50
VMK NW 40 HL	L	PN 160	42	M 48 x 2 K	22	42,0	38,0	55	60
VMK NW 03 HS	S	PN 630	6	M 12 x 1.5 K	12	40,0	24,0	17	17
VMK NW 04 HS	S	PN 630	8	M 14 x 1.5 K	12	42,0	25,0	17	19
VMK NW 06 HS	S	PN 630	10	M 16 x 1.5 K	12	43,0	24,5	19	22
VMK NW 08 HS	S	PN 630	12	M 18 x 1.5 K	12	45,0	26,5	22	24
VMK NW 10 HS	S	PN 630	14	M 20 x 1.5 K	14	51,0	30,0	24	27
VMK NW 13 HS	S	PN 400	16	M 22 x 1.5 K	14	51,0	31,5	27	30
VMK NW 16 HS	S	PN 400	20	M 27 x 2 K	18	60,0	35,5	32	36
VMK NW 20 HS	S	PN 400	25	M 33 x 2 K	20	67,0	38,0	41	46
VMK NW 25 HS	S	PN 400	30	M 42 x 2 K	21	71,0	40,5	56	50
VMK NW 32 HS	S	PN 315	38	M 48 x 2 K	22	79,0	44,0	55	60

结构系列:LL=非常轻 L=轻 S=重 - PN = 额定压力 PB = 最大工作压力 - Ø = 管外径

产品变体

VMK MG	旋入式螺栓连接, 黄铜
VMK VA	旋入式螺栓连接, 不锈钢
XVMK	旋入式螺栓连接, 钢