

属性

接口 1	米制外螺纹,圆柱形
密封形式 1	F型
接口 2	米制外螺纹,圆柱形
密封形式 2	24°内锥
结构类型	旋入式螺栓连接
结构形式	直道
标准	ISO 8434-1
供货范围	带锁紧螺母和切割环的接套
原料	钢
表面保护	电镀涂层

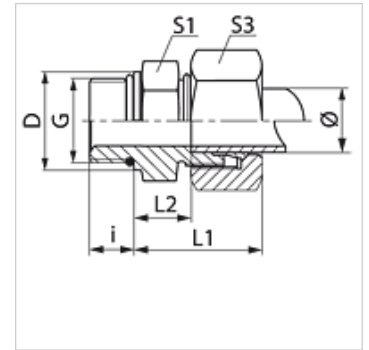

提示

有关安装、装入、压力负荷和允许的工作温度的说明请您参阅管螺栓连接的技术信息。

货品

名称	结构系列	工作压力 巴	管外径 Ø (mm)	G	D (mm)	i (mm)	L1 (mm)	L2 (mm)	S1	S3	OR
VMO 04 LL	LL	PN 100	4	M 8 x 1	10,8	6,5	19,0	9,5	11	10	6.1 x 1.6
VMO 04 LL 10	LL	PN 100	4	M 10 x 1	12,8	6,5	19,0	9,5	13	10	8.0 x 1.5
VMO 06 LL	LL	PN 100	6	M 10 x 1	12,8	6,5	19,5	8,0	13	12	8.0 x 1.5
VMO NW 04 HL	L	PN 250	6	M 10 x 1	14,0	8,0	23,0	8,5	14	14	8.0 x 1.5
VMO NW 06 HL	L	PN 250	8	M 12 x 1.5	17,0	12,0	25,0	10,0	17	17	9.3 x 2.4
VMO NW 08 HL	L	PN 250	10	M 14 x 1.5	19,0	12,0	26,0	11,0	19	19	11.3 x 2.4
VMO NW 10 HL	L	PN 250	12	M 16 x 1.5	22,0	12,0	27,0	12,5	22	22	13.3 x 2.4
VMO NW 13 HL	L	PN 250	15	M 18 x 1.5	24,0	12,0	29,0	13,5	24	27	15.3 x 2.4
VMO NW 16 HL	L	PN 160	18	M 22 x 1.5	27,0	14,0	32,0	14,5	27	32	19.3 x 2.4
VMO NW 20 HL	L	PN 160	22	M 26 x 1.5	31,0	16,0	34,0	16,5	32	36	23.3 x 2.4
VMO NW 20 HL 27	L	PN 160	22	M 27 x 2	32,0	16,0	33,0	16,5	32	36	23.6 x 2.9
VMO NW 25 HL	L	PN 100	28	M 33 x 2	41,0	18,0	34,0	17,5	41	41	29.5 x 3.0
VMO NW 32 HL	L	PN 100	35	M 42 x 2	50,0	20,0	39,0	17,5	50	50	38.0 x 3.0
VMO NW 40 HL	L	PN 160	42	M 48 x 2	55,0	17,5	42,0	19,0	55	60	44.60 x 3.00
VMO NW 03 HS	S	PN 630	6	M 12 x 1.5	17,0	12,0	28,0	13,0	17	17	9.3 x 2.4
VMO NW 04 HS	S	PN 630	8	M 14 x 1.5	19,0	12,0	30,0	15,0	19	19	11.3 x 2.4
VMO NW 06 HS	S	PN 630	10	M 16 x 1.5	22,0	12,0	31,0	15,0	22	22	13.3 x 2.4
VMO NW 08 HS	S	PN 630	12	M 18 x 1.5	24,0	12,0	33,0	17,0	24	24	15.3 x 2.4
VMO NW 13 HS	S	PN 400	16	M 22 x 1.5	27,0	14,0	37,0	18,5	27	30	19.3 x 2.4
VMO NW 16 HS	S	PN 400	20	M 27 x 2	32,0	16,0	41,0	20,5	32	36	23.5 x 3.0
VMO NW 20 HS	S	PN 400	25	M 33 x 2	41,0	18,0	47,0	23,0	41	46	29.5 x 3.0
VMO NW 25 HS	S	PN 250	30	M 42 x 2	50,0	20,0	50,0	23,5	50	50	38.0 x 3.0
VMO NW 32 HS	S	PN 315	38	M 48 x 2	55,0	21,5	57,0	26,0	55	60	44.6 x 2.9

结构系列: LL=非常轻 L=轻 S=重 - PN = 额定压力 PB = 最大工作压力 - Ø = 管外径

产品变体

XVMO