

属性

接口 1	BSP内螺纹,圆柱形
密封形式 1	A型
接口 2	米制外螺纹,圆柱形
密封形式 2	24°内锥
结构类型	旋上式螺栓连接
结构形式	直道
标准	DIN 2353 ISO 8434-1
供货范围	接套(不带锁紧螺母和切割环)
原料	钢
表面保护	电镀涂层

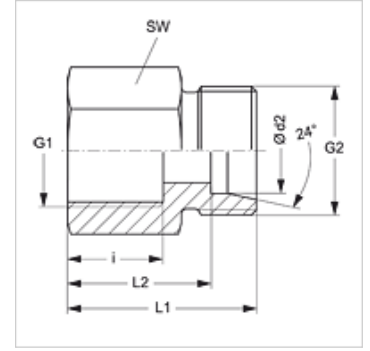

提示

有关安装、装入、压力负荷和允许的工作温度的说明请您参阅管螺栓连接的技术信息。

货品

名称	结构系列	工作压力 巴	Ø d2 (mm)	G1	G2	i (mm)	L1 (mm)	L2 (mm)	SW (mm)
XGAR NW 04 HL	L	PN 315	6	G 1/8" -28	M 12 x 1.5	12,0	26,0	19,0	14
XGAR NW 04 HL 1/4	L	PN 315	6	G 1/4" -19	M 12 x 1.5	17,0	31,0	24,0	19
XGAR NW 04 HL 3/8	L	PN 315	6	G 3/8" -19	M 12 x 1.5	17,0	32,0	25,0	22
XGAR NW 06 HL	L	PN 315	8	G 1/4" -19	M 14 x 1.5	17,0	31,0	24,0	19
XGAR NW 06 HL 3/8	L	PN 315	8	G 3/8" -19	M 14 x 1.5	17,0	32,0	25,0	22
XGAR NW 06 HL 1/2	L	PN 315	8	G 1/2" -14	M 14 x 1.5	20,0	36,0	29,0	27
XGAR NW 08 HL	L	PN 315	10	G 1/4" -19	M 16 x 1.5	17,0	32,0	25,0	19
XGAR NW 08 HL 3/8	L	PN 315	10	G 3/8" -19	M 16 x 1.5	17,0	33,0	26,0	22
XGAR NW 08 HL 1/2	L	PN 315	10	G 1/2" -14	M 16 x 1.5	20,0	37,0	30,0	27
XGAR NW 10 HL 1/4	L	PN 315	12	G 1/4" -19	M 18 x 1.5	17,0	32,0	25,0	19
XGAR NW 10 HL	L	PN 315	12	G 3/8" -19	M 18 x 1.5	17,0	33,0	26,0	22
XGAR NW 10 HL 1/2	L	PN 315	12	G 1/2" -14	M 18 x 1.5	20,0	37,0	30,0	27
XGAR NW 13 HL 3/8	L	PN 315	15	G 3/8" -19	M 22 x 1.5	17,0	34,0	27,0	24
XGAR NW 13 HL	L	PN 315	15	G 1/2" -14	M 22 x 1.5	20,0	38,0	31,0	27
XGAR NW 16 HL	L	PN 315	18	G 1/2" -14	M 26 x 1.5	20,0	38,0	30,5	27
XGAR NW 20 HL	L	PN 160	22	G 3/4" -14	M 30 x 2	22,0	43,0	35,5	32
XGAR NW 25 HL	L	PN 160	28	G 1" -11	M 36 x 2	24,5	45,5	38,0	41
XGAR NW 32 HL	L	PN 160	35	G 1.1/4" -11	M 45 x 2	26,5	51,5	41,0	50
XGAR NW 40 HL	L	PN 160	42	G 1.1/2" -11	M 52 x 2	28,5	53,5	42,5	55
XGAR NW 03 HS	S	PN 400	6	G 1/4" -19	M 14 x 1.5	17,0	33,0	26,0	19
XGAR NW 04 HS	S	PN 400	8	G 1/4" -19	M 16 x 1.5	17,0	33,0	26,0	19
XGAR NW 06 HS	S	PN 400	10	G 3/8" -19	M 18 x 1.5	17,0	34,0	26,5	24
XGAR NW 08 HS	S	PN 400	12	G 3/8" -19	M 20 x 1.5	17,0	34,0	26,5	24
XGAR NW 10 HS	S	PN 400	14	G 1/2" -14	M 22 x 1.5	20,0	40,0	32,0	27
XGAR NW 13 HS	S	PN 400	16	G 1/2" -14	M 24 x 1.5	20,0	40,0	31,5	27
XGAR NW 16 HS	S	PN 315	20	G 3/4" -14	M 30 x 2	22,0	45,0	34,5	36
XGAR NW 20 HS	S	PN 315	25	G 1" -11	M 36 x 2	24,5	49,5	37,5	41
XGAR NW 25 HS	S	PN 315	30	G 1.1/4" -11	M 42 x 2	26,5	55,5	42,0	50
XGAR NW 32 HS	S	PN 250	38	G 1.1/2" -11	M 52 x 2	28,5	59,5	43,5	60

结构系列: LL=非常轻 L=轻 S=重 - PN = 额定压力 PB = 最大工作压力 - Ø d2 = 管外直径

产品变体

XGAR VA	旋上式螺栓连接, 不锈钢
GAR	旋上式螺栓连接, 钢