

属性

接口 1	米制外螺纹,圆柱形
密封形式 1	24°内锥
接口 2	米制外螺纹,圆柱形
密封形式 2	24°内锥
结构类型	螺栓连接
结构形式	直道
标准	ISO 8434-1
供货范围	接套(不带锁紧螺母和切割环)
原料	钢
表面保护	电镀涂层

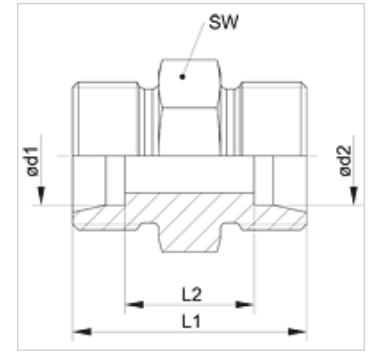

提示

有关安装、装入、压力负荷和允许的工作温度的说明请您参阅管螺栓连接的技术信息。

货品

名称	结构系列	工作压力 巴	Ø d1 (mm)	Ø d2 (mm)	L1 (mm)	L2 (mm)	SW (mm)
XV 04 LL	LL	PN 100	4	4	20	12,0	9
XV 05 LL	LL	PN 100	5	5	20	9,0	11
XV 06 LL 04	LL	PN 100	6	4	20	10,5	11
XV 06 LL	LL	PN 100	6	6	20	9,0	11
XV 08 LL 04	LL	PN 100	8	4	22	12,5	12
XV 08 LL 06	LL	PN 100	8	6	22	11,0	12
XV 08 LL	LL	PN 100	8	8	23	12,0	12
XV 10 LL	LL	PN 100	10	10	23	12,0	14
XV 12 LL	LL	PN 100	12	12	23	11,0	17
XV NW 04 HL	L	PN 315	6	6	24	10,0	12
XV NW 06 HL 04	L	PN 315	8	6	25	11,0	14
XV NW 06 HL	L	PN 315	8	8	25	11,0	14
XV NW 08 HL 04	L	PN 315	10	6	26	12,0	17
XV NW 08 HL 06	L	PN 315	10	8	26	12,0	17
XV NW 08 HL	L	PN 315	10	10	27	13,0	17
XV NW 10 HL 04	L	PN 315	12	6	27	13,0	19
XV NW 10 HL 06	L	PN 315	12	8	27	13,0	19
XV NW 10 HL 08	L	PN 315	12	10	28	14,0	19
XV NW 10 HL	L	PN 315	12	12	28	14,0	19
XV NW 13 HL 04	L	PN 315	15	6	28	14,0	24
XV NW 13 HL 06	L	PN 315	15	8	28	14,0	24
XV NW 13 HL 08	L	PN 315	15	10	29	15,0	24
XV NW 13 HL 10	L	PN 315	15	12	29	15,0	24
XV NW 13 HL	L	PN 315	15	15	30	16,0	24
XV NW 16 HL 04	L	PN 315	18	6	29	14,5	27
XV NW 16 HL 06	L	PN 315	18	8	29	14,5	27
XV NW 16 HL 08	L	PN 315	18	10	30	15,5	27
XV NW 16 HL 10	L	PN 315	18	12	30	15,5	27
XV NW 16 HL 10 27	L	PN 315	18	12	32	17,5	27
XV NW 16 HL 13	L	PN 315	18	15	31	16,5	27
XV NW 16 HL	L	PN 315	18	18	31	16,0	27
XV NW 16 HL 27	L	PN 315	18	18	35	20,0	27
XV NW 20 HL 06	L	PN 160	22	8	31	16,5	32
XV NW 20 HL 08	L	PN 160	22	10	32	17,5	32
XV NW 20 HL 10	L	PN 160	22	12	32	17,5	32
XV NW 20 HL 13	L	PN 160	22	15	33	18,5	32
XV NW 20 HL 16	L	PN 160	22	18	33	18,0	32
XV NW 20 HL 16 27	L	PN 160	22	18	35	20,0	32
XV NW 20 HL	L	PN 160	22	22	35	20,0	32
XV NW 25 HL 06	L	PN 160	28	8	33	18,5	41
XV NW 25 HL 08	L	PN 160	28	10	34	19,5	41
XV NW 25 HL 10	L	PN 160	28	12	34	19,5	41
XV NW 25 HL 13	L	PN 160	28	15	35	20,5	41



货品

名称	结构系列	工作压力 巴	Ø d1 (mm)	Ø d2 (mm)	L1 (mm)	L2 (mm)	SW (mm)
XV NW 25 HL 16	L	PN 160	28	18	35	20,0	41
XV NW 25 HL 16 27	L	PN 160	28	18	37	22,0	41
XV NW 25 HL 20	L	PN 160	28	22	37	22,0	41
XV NW 25 HL	L	PN 160	28	28	36	21,0	41
XV NW 32 HL 20	L	PN 160	35	22	39	21,0	46
XV NW 32 HL 25	L	PN 160	35	28	39	21,0	46
XV NW 32 HL	L	PN 160	35	35	41	20,0	46
XV NW 40 HL 25	L	PN 160	42	28	41	22,5	55
XV NW 40 HL 32	L	PN 160	42	35	43	21,5	55
XV NW 40 HL	L	PN 160	42	42	66	21,0	55
XV NW 16 HL 13 HS	L / S	PN 315	18	16	33	17,0	27
XV NW 03 HS	S	PN 630	6	6	30	16,0	14
XV NW 04 HS 03	S	PN 630	8	6	32	18,0	17
XV NW 04 HS	S	PN 630	8	8	32	18,0	17
XV NW 06 HS 03	S	PN 630	10	6	32	17,5	19
XV NW 06 HS 04	S	PN 630	10	8	32	17,5	19
XV NW 06 HS	S	PN 630	10	10	32	17,0	19
XV NW 08 HS 03	S	PN 630	12	6	34	19,5	22
XV NW 08 HS 04	S	PN 630	12	8	34	19,5	22
XV NW 08 HS 06	S	PN 630	12	10	34	19,0	22
XV NW 08 HS	S	PN 630	12	12	34	19,0	22
XV NW 10 HS 03	S	PN 630	14	6	36	21,0	24
XV NW 10 HS 04	S	PN 630	14	8	36	21,0	24
XV NW 10 HS 06	S	PN 630	14	10	36	20,5	24
XV NW 10 HS 08	S	PN 630	14	12	36	20,5	24
XV NW 10 HS	S	PN 630	14	14	38	22,0	24
XV NW 13 HS 03	S	PN 400	16	6	36	20,5	27
XV NW 13 HS 04	S	PN 400	16	8	36	20,5	27
XV NW 13 HS 06	S	PN 400	16	10	36	20,0	27
XV NW 13 HS 08	S	PN 400	16	12	36	20,0	27
XV NW 13 HS 10	S	PN 400	16	14	38	21,5	27
XV NW 13 HS	S	PN 400	16	16	38	21,0	27
XV NW 16 HS 06	S	PN 400	20	10	40	22,0	32
XV NW 16 HS 08	S	PN 400	20	12	40	22,0	32
XV NW 16 HS 10	S	PN 400	20	14	42	23,5	32
XV NW 16 HS 13	S	PN 400	20	16	42	23,0	32
XV NW 16 HS	S	PN 400	20	20	44	23,0	32
XV NW 20 HS 13	S	PN 400	25	16	46	25,5	41
XV NW 20 HS 16	S	PN 400	25	20	48	25,5	41
XV NW 20 HS	S	PN 400	25	25	50	26,0	41
XV NW 25 HS 13	S	PN 400	30	16	48	26,0	46
XV NW 25 HS 16	S	PN 400	30	20	50	26,0	46
XV NW 25 HS 20	S	PN 400	30	25	52	26,5	46
XV NW 25 HS	S	PN 400	30	30	54	27,0	46
XV NW 32 HS 13	S	PN 315	38	16	53	28,5	55
XV NW 32 HS 20	S	PN 315	38	25	57	29,0	55
XV NW 32 HS 25	S	PN 315	38	30	59	29,5	55
XV NW 32 HS	S	PN 315	38	38	61	29,0	55
XV NW 13 HS 13 HL	S / L	PN 400	16	15	36	20,5	27
XV NW 16 HS 13 HL	S / L	PN 400	20	15	40	22,5	32
XV NW 16 HS 16 HL	S / L	PN 400	20	18	40	22,0	32
XV NW 20 HS 20 HL	S / L	PN 400	25	22	46	26,5	41

结构系列:LL=非常轻 L=轻 S=重 - PN = 额定压力 PB = 最大工作压力 - Ø d1 = 管外直径 - Ø d2 = 管外直径

产品变体

XV VA	螺栓连接, 不锈钢
V-LL / V-HL / V-HS	螺栓连接, 钢