

AFS 90 ST M (3000 / 6000 PSI)

SAE焊接法兰,角度90°

HANSA FLEX

属性

标准	SAE J 518 C ISO 6162
结构形式	角度90°
结构类型	SAE焊接法兰
固定	带米制螺钉组件
供货范围	带米制螺钉组件和O形圈
原料	S355J2G3 (ST52.3)
表面保护	经黑色润滑油处理

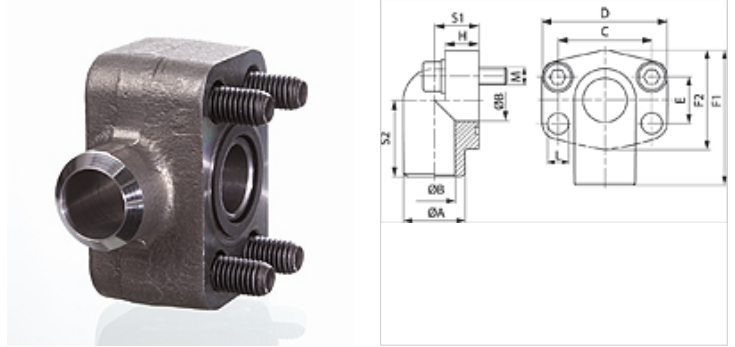

提示

给出的最大工作压力针对的是法兰!实际工作压力视管(壁厚)和管的品质而定!

货品

名称	压力系列	PB 10.9 (bar)	结构尺 寸	Ø A (mm)	Ø B (mm)	C (mm)	D (mm)	E (mm)	F1 (mm)	F2 (mm)	H (mm)	S1 (mm)	S2 (mm)	L (mm)	螺钉
AFS 200/90 ST M	3000 PSI	350	3/4"	27,0	19	47,6	70	22,2	63	50	21,0	23,0	41	11,0	(4 x) M 10 x 40
AFS 202/90 ST M	3000 PSI	315	1"	34,5	23	52,4	75	26,2	72	60	24,0	25,0	48	11,0	(4 x) M 10 x 45
AFS 204/90 ST M	3000 PSI	250	1.1/4"	43,0	31	58,7	86	30,2	82	68	25,0	27,0	54	11,5	(4 x) M 10 x 45
AFS 206/90 ST M	3000 PSI	200	1.1/2"	50,0	35	69,9	97	35,7	92	78	29,0	31,5	57	14,0	(4 x) M 12 x 50
AFS 208/90 ST M	3000 PSI	200	2"	65,0	48	77,8	100	42,9	99	90	50,0	37,5	63	14,0	(4 x) M 12 x 70
AFS 700/90 ST M	6000 PSI	400	3/4"	28,0	19	50,8	71	23,8	70	60	19,0	22,0	40	11,0	(4 x) M 10 x 35
AFS 702/90 ST M	6000 PSI	400	1"	35,0	25	57,2	81	27,8	82	70	24,0	27,0	47	13,0	(4 x) M 10 x 45
AFS 704/90 ST M	6000 PSI	375	1.1/4"	42,0	32	66,7	95	31,8	95	78	27,0	32,0	56	15,0	(4 x) M 14 x 50
AFS 706/90 ST M	6000 PSI	320	1.1/2"	48,0	38	79,4	113	36,5	115	94	30,0	40,0	68	17,0	(4 x) M 16 x 50

PN = 额定压力 PB = 最大工作压力

产品变体

AFS 90 ST (3000 PSI) SAE焊接法兰,角度90°, 仅法兰