

GFS SRE (3000 / 6000 PSI)

SAE焊接对接法兰

HANSA FLEX

属性

标准	SAE J 518 C ISO 6162
结构形式	直道
结构类型	SAE焊接对接法兰
固定	米制螺钉用内螺纹
原料	S355J2G3 (ST52.3)
表面保护	经黑色润滑油处理

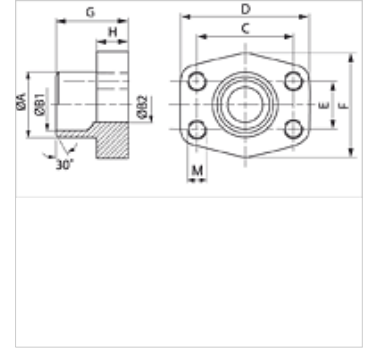
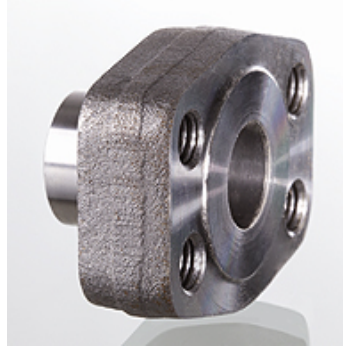

提示

给出的最大工作压力针对的是法兰!实际工作压力视管(壁厚)和管的品质而定!

货品

名称	PB 10.9 (bar)	结构尺寸	管	A (mm)	B1 (mm)	B2 (mm)	G (mm)	C (mm)	D (mm)	E (mm)	F (mm)	H (mm)	M 米制
GFS 80 SRE 20	350	1/2"	20 x 3	20	14,0	14	35,0	38,1	54	17,5	46	16,0	M 8
GFS 80 SRE 22	350	1/2"	22 x 3	22	16,0	13	35,0	38,1	54	17,5	46	16,0	M 8
GFS 100 SRE 25	350	3/4"	25 x 3	25	19,0	19	36,0	47,6	65	22,2	50	18,0	M 10
GFS 100 SRE 28	350	3/4"	28 x 3	28	21,5	19	36,0	47,6	65	22,2	50	18,0	M 10
GFS 102 SRE 30	315	1"	30 x 4	30	22,0	22	38,0	52,4	70	26,2	55	18,0	M 10
GFS 102 SRE 35	315	1"	35 x 4	35	27,0	25	38,0	52,4	70	26,2	55	18,0	M 10
GFS 104 SRE 38	250	1.1/4"	38 x 4	38	30,0	30	41,0	58,7	79	30,2	68	21,0	M 10
GFS 104 SRE 42	250	1.1/4"	42 x 3	43	36,0	31	41,0	58,7	79	30,2	68	21,0	M 10
GFS 106 SRE 38	200	1.1/2"	38 x 4	38	30,0	30	44,0	69,9	93	35,7	78	25,0	M 12
GFS 106 SRE 42	200	1.1/2"	42 x 3	42	36,0	36	44,0	69,9	93	35,7	78	25,0	M 12
GFS 106 SRE 48	200	1.1/2"	48.3 x 4.5	49	38,0	38	44,0	69,9	93	35,7	78	25,0	M 12
GFS 108 SRE 60	200	2"	60.3 x 5.6	61	49,0	49	45,0	77,8	102	42,9	90	25,0	M 12
GFS 110 SRE 76	160	2.1/2"	76.1 x 7.1	77	62,0	62	50,0	88,9	114	50,8	105	25,0	M 12
GFS 112 SRE 76	138	3"	76.1 x 7.1	77	62,0	62	51,0	106,4	134	61,9	125	26,0	M 16
GFS 401 SRE 20	400	1/2"	20 x 3	20	14,0	14	34,0	40,5	54	18,2	46	16,0	M 8
GFS 402 SRE 20	400	3/4"	20 x 3	20	14,0	14	35,0	50,8	71	23,8	55	21,0	M 10
GFS 402 SRE 25	400	3/4"	25 x 4	25	17,0	17	35,0	50,8	71	23,8	55	21,0	M 10
GFS 403 SRE 25	400	1"	25 x 4	25	17,0	17	42,0	57,2	81	27,8	65	25,0	M 12
GFS 403 SRE 30	400	1"	30 x 4	30	22,0	22	42,0	57,2	81	27,8	65	25,0	M 12
GFS 404 SRE 30	400	1.1/4"	30 x 4	30	22,0	22	44,0	66,7	95	31,8	78	25,0	M 14
GFS 404 SRE 38	400	1.1/4"	38 x 6	38	26,0	26	44,0	66,7	95	31,8	78	25,0	M 14
GFS 405 SRE 38	400	1.1/2"	38 x 6	38	26,0	26	56,0	79,4	112	36,5	94	28,0	M 16
GFS 405 SRE 48	400	1.1/2"	48.3 x 8	49	32,0	32	56,0	79,4	112	36,5	94	28,0	M 16
GFS 405 SRE 60	400	1.1/2"	60.3 x 10	61	40,0	40	56,0	79,4	112	36,5	94	28,0	M 16
GFS 406 SRE 60	400	2"	60.3 x 10	61	40,0	40	65,0	96,8	134	44,5	114	33,0	M 20
GFS 406 SRE 76	400	2"	76.1 x 12.5	76	48,0	48	80,0	96,8	134	44,5	114	33,0	M 20

PN = 额定压力 PB = 最大工作压力