

G AJ HBED VA

连接器

HANSA FLEX

属性

接口 1	UN/UNF螺母螺纹
密封形式 1	74°内锥
接口 2	BSP外螺纹,圆柱形
密封形式 2	60°内锥 + E型
结构类型	连接器
结构形式	直道
原料	不锈钢

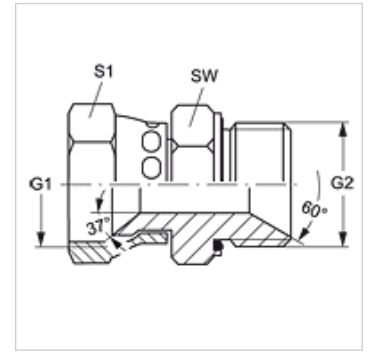

订购指南

NBR 材料制成的密封件
FPM (氟胶) 应客户要求提供

货品

名称	G1	G2	SW (mm)	S1
G AJ 04 HB 02 ED VA	7/16" -20 UNF	G 1/8" -28	14	17
G AJ 04 HBED VA	7/16" -20 UNF	G 1/4" -19	19	17
G AJ 05 HB 04 ED VA	1/2" -20 UNF	G 1/4" -19	19	17
G AJ 06 HB 04 ED VA	9/16" -18 UNF	G 1/4" -19	19	19
G AJ 06 HBED VA	9/16" -18 UNF	G 3/8" -19	22	19
G AJ 08 HB 06 ED VA	3/4" -16 UNF	G 3/8" -19	32	24
G AJ 08 HBED VA	3/4" -16 UNF	G 1/2" -14	27	24
G AJ 10 HB 08 ED VA	7/8" -14 UNF(细牙系列)	G 1/2" -14	27	27
G AJ 12 HBED VA	1.1/16" -12 UN	G 3/4" -14	32	32
G AJ 12 HB 16 ED VA	1.1/16" -12 UN	G 1" -11	41	32
G AJ 16 HB 12 ED VA	1.5/16" -12 UN	G 3/4" -14	32	41
G AJ 16 HBED VA	1.5/16" -12 UN	G 1" -11	41	41
G AJ 20 HB 16 ED VA	1.5/8" -12 UN	G 1" -11	41	50
G AJ 20 HBED VA	1.5/8" -12 UN	G 1.1/4" -11	50	50
G AJ 24 HB 20 ED VA	1.7/8" -12 UN	G 1.1/4" -11	50	55
G AJ 24 HBED VA	1.7/8" -12 UN	G 1.1/2" -11	55	55

SW, S1, S2 = 对应边宽度

备件

WD V 用于ED螺栓连接的软密封