

SV HJ IN

隔离螺栓连接接套

属性

| | |
|--------|-----------|
| 接口 1 | UN/UNF外螺纹 |
| 密封形式 1 | 74°外锥 |
| 接口 2 | NPT内螺纹 |
| 密封形式 2 | 螺纹密封 |
| 结构类型 | 隔离螺栓连接接套 |
| 结构形式 | 直道 |
| 原料 | 钢 |
| 表面保护 | 电镀涂层 |

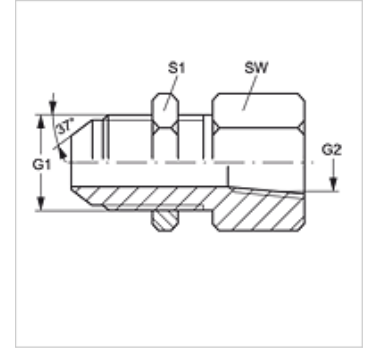

货品

| 名称 | G1 | G2 | SW (mm) | S1 |
|----------------|--------------------|------------------|------------|----|
| SV HJ 04 IN 02 | 7/16" -20 UNF | 1/8" -27 NPT | 17 | 17 |
| SV HJ 04 IN | 7/16" -20 UNF | 1/4" -18 NPT | 19 | 19 |
| SV HJ 05 IN 02 | 1/2" -20 UNF | 1/8" -27 NPT | 21 | 17 |
| SV HJ 05 IN 04 | 1/2" -20 UNF | 1/4" -18 NPT | 19 | 17 |
| SV HJ 06 IN 02 | 9/16" -18 UNF | 1/8" -27 NPT | 17 | 21 |
| SV HJ 06 IN 04 | 9/16" -18 UNF | 1/4" -18 NPT | 21 | 21 |
| SV HJ 06 IN | 9/16" -18 UNF | 3/8" -18 NPT | 25 | 21 |
| SV HJ 08 IN 04 | 3/4" -16 UNF | 1/4" -18 NPT | 21 | 25 |
| SV HJ 08 IN 06 | 3/4" -16 UNF | 3/8" -18 NPT | 25 | 25 |
| SV HJ 08 IN | 3/4" -16 UNF | 1/2" -14 NPT | 29 | 25 |
| SV HJ 10 IN 08 | 7/8" -14 UNF(细牙系列) | 1/2" -14 NPT | 29 | 29 |
| SV HJ 12 IN 08 | 1.1/16" -12 UN | 1/2" -14 NPT | 29 | 35 |
| SV HJ 12 IN | 1.1/16" -12 UN | 3/4" -14 NPT | 35 | 35 |
| SV HJ 14 IN 12 | 1.3/16" -12 UN | 3/4" -14 NPT | 35 | 41 |
| SV HJ 16 IN | 1.5/16" -12 UN | 1" -11.5 NPT | 41 | 41 |
| SV HJ 20 IN | 1.5/8" -12 UN | 1.1/4" -11.5 NPT | 46 | 46 |
| SV HJ 24 IN | 1.7/8" -12 UN | 1.1/2" -11.5 NPT | 50 | 50 |

SW, S1, S2 = 对应边宽度