

属性

接口	油接口:A + B = G 1/2"; 渗油 = G 1/4"
规格	标准型 Type "C" with standard seal Four hole flange bolt circle 106,4 轴Ø 32mm
带渗油管道的入口和回流压力 max.	210 bar

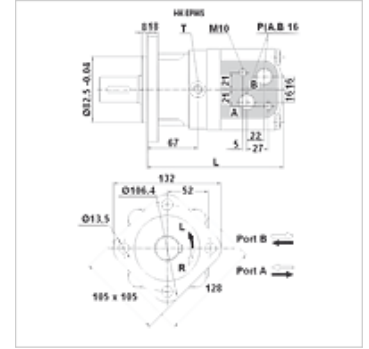

提示

建议连接漏油管线!

货品

名称	流量 max. (L/min)	排量 (cc)	转速 min. (rpm)	转速 max. (rpm)	扭矩 max. (N-m)	压力落差 max. (bar)	Pmax. at 0-100 rpm (bar)	Pmax. at 100-300 rpm (bar)	Pmax. at 300 rpm (bar)	L (mm)	重量 (kg)
HK EPMS 080 C	65	80,5	10	810	200	175	100	50	20	166	9,8
HK EPMS 100 C	75	100,0	10	750	290	175	100	50	20	169	10,0
HK EPMS 125 C	75	125,7	8	600	370	175	100	50	20	174	10,3
HK EPMS 160 C	75	159,7	8	470	460	150	100	50	20	180	10,7
HK EPMS 200 C	75	200,0	8	375	460	140	100	50	20	187	11,1
HK EPMS 250 C	75	250,0	8	300	500	125	100	50	-	195	11,6
HK EPMS 315 C	75	314,9	8	240	540	120	100	50	-	207	12,3
HK EPMS 400 C	75	397,0	8	185	580	100	100	50	-	221	13,2

max. pressure on shaft seal (without leak oil line) or pressure in leak oil line – 扭矩和压力落差的数值适用于持续运行状态 – pmax.= 最大压力

附件

HK V0 590 冲击阀

备件

HK EP DS 用于液行星马达的密封组件