

属性
规格 右转

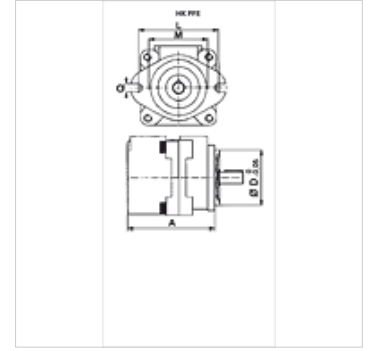

提示
转速1500转/分钟,液压油粘度24 mm²/s和40°C时的性能数据

描述
定量泵,转子芯中12个叶片
用于高压运行的液压轴向间隙补偿
低噪音

名称	VFU (cc)	压力 max. (bar)	n min. (rpm)	n max. (rpm)	7巴时Qmax max. (L/min)	210巴时 Qmax max. (L/min)	Ø 轴 (mm)	A (mm)	压力接 口 SAE	抽吸接 口 SAE	D (mm)	L (mm)	M (mm)	Q (mm)	重量 (kg)
HK PFE 31 016 1DT	16,5	210	800	2800	23	16	19,05	134,5	3/4"	1.1/4"	82,5	106	73,0	11,1	9,00
HK PFE 31 022 1DT	21,6	210	800	2800	30	23	19,05	134,5	3/4"	1.1/4"	82,5	106	73,0	11,1	9,00
HK PFE 31 028 1DT	28,0	210	800	2800	40	33	19,05	134,5	3/4"	1.1/4"	82,5	106	73,0	11,1	9,00
HK PFE 31 036 1DT	35,6	210	800	2800	51	43	19,05	134,5	3/4"	1.1/4"	82,5	106	73,0	11,1	9,00
HK PFE 41 045 1DT	45,0	210	800	2500	64	57	22,22	160,0	1"	1.1/2"	101,6	146	107,0	14,3	14,00
HK PFE 41 056 1DT	55,8	210	800	2500	80	72	22,22	160,0	1"	1.1/2"	101,6	146	107,0	14,3	14,00
HK PFE 41 070 1DT	69,9	210	800	2500	101	91	22,22	160,0	1"	1.1/2"	101,6	146	107,0	14,3	14,00
HK PFE 41 085 1DT	85,3	210	800	2000	124	114	22,22	189,0	1"	1.1/2"	101,6	146	107,0	14,3	14,00
HK PFE 51 150 1DT	150,0	210	800	1800	215	197	31,75	186,5	1.1/4"	2"	127,0	181	143,5	17,5	26,00
HK PFE 52 090 3DT	90,0	250	1000	2000	128	111	34,88	189,0	1.1/4"	2"	127,0	181	143,5	17,5	32,14
HK PFE 52 110 3DT	109,6	250	1000	2200	157	138	34,88	189,0	1.1/4"	2"	127,0	181	143,5	17,5	32,14
HK PFE 52 129 3DT	129,2	250	1000	2200	186	163	34,88	189,0	1.1/4"	2"	127,0	181	143,5	17,5	32,14

VFU = 每转一圈的输送容量 - n = 转速