

AC OR

用于AC-Clip内接头的O形圈

属性

结构类型 用于AC-Clip内接头的密封圈

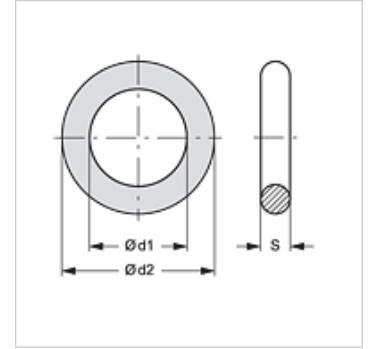

货品

名称	用于软管 DN	$\varnothing d1$ (mm)	$\varnothing d2$ (mm)	S (mm)
AC OR 05	05	3,5	5,5	1,0
AC OR 08	08	5,5	7,5	1,0
AC OR 10	10	8,0	10,0	1,0
AC OR 13	12	9,5	12,5	1,5
AC OR 16	16	12,0	16,0	2,0
AC OR 20	19	15,5	19,5	2,0