

K-BR POM BLAU

Single banjos

HANSA FLEX

属性

工作压力 0 - 10 bar

温度范围 -10 °C to +60 °C

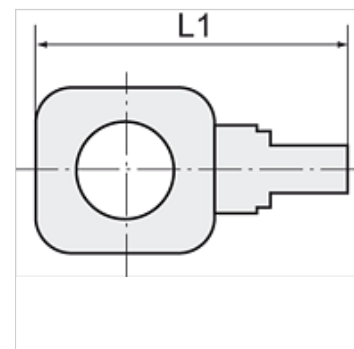
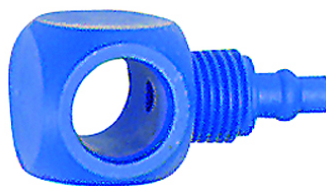

提示

其它数据应客户要求提供。

货品

名称	螺纹	用于软管	L1 (mm)
K- 07 40 33 34	for G 1/8	6 mm / 4 mm	31,0
K- 07 40 33 35	for G 1/8	8 mm / 6 mm	33,0
K- 07 40 33 36	for G 1/4	6 mm / 4 mm	35,0
K- 07 40 33 37	for G 1/4	8 mm / 6 mm	36,5